



**PRECISION CONSTANT
CURRENT SOURCES
MODELS 6177C AND 6181C**

OPERATING AND SERVICE MANUAL FOR:

MODEL 6177C, SERIALS 1525A-00101 AND ABOVE

MODEL 6181C, SERIALS 1525A-00101 AND ABOVE

For serials above 1525A-00101
a change page may be included.

Hewlett-Packard

TABLE OF CONTENTS

Section	Page No.	Section	Page No.
I GENERAL INFORMATION	1-1	IV PRINCIPLES OF OPERATION . . (Continued)	
1-1 Description	1-1	4-16 Detailed Circuit Description	4-3
1-8 Specifications	1-1	4-17 Reference Supply	4-3
1-10 Options	1-1	4-21 Guard Supply	4-3
1-12 Accessories	1-2	4-25 Constant Current Comparator	4-4
1-14 Instrument Identification	1-2	4-30 Driver and Series Regulator	4-4
1-17 Ordering Additional Manuals	1-2	4-34 Turn-On/Turn-Off Control	4-4
		4-37 Voltage Limit Programming	
		Current Source	4-4
II INSTALLATION	2-1	4-39 Voltage Limit Circuit	4-5
2-1 Initial Inspection	2-1	4-42 Voltage Limit Light Circuit	4-5
2-3 Mechanical Check	2-1	4-44 Bleed Circuit	4-5
2-5 Electrical Check	2-1		
2-7 Installation Data	2-1	V MAINTENANCE.	5-1
2-9 Location	2-1	5-1 Introduction	5-1
2-11 Outline Diagram	2-1	5-3 Test Equipment Required	5-1
2-13 Rack Mounting	2-1	5-5 Performance Test	5-2
2-16 Input Power Requirements	2-2	5-7 Constant Current Tests	5-2
2-18 Changing the Line Voltage		5-10 Rated Output and Meter	
Option	2-2	Accuracy	5-3
2-20 Power Cable	2-2	5-13 Load Effect (Load Regula-	
2-24 Repackaging for Shipment	2-2	tion)	5-3
		5-15 Source Effect (Line Regula-	
III OPERATING INSTRUCTIONS.	3-1	tion)	5-4
3-1 Turn-On Checkout Procedure	3-1	5-17 PARD (Ripple and Noise)	5-4
3-3 Operating Modes	3-1	5-29 Programming Speed	5-7
3-6 Normal Operating Mode	3-2	5-31 Output Stability	5-7
3-8 Constant Current	3-2	5-34 Temperature Coefficient	5-8
3-10 Connecting Load	3-2	5-38 Troubleshooting	5-8
3-12 Operation of Supply Beyond		5-43 Initial Troubleshooting	
Rated Output	3-2	Procedures	5-8
3-14 Optional Operating Modes	3-3	5-45 Adjustment and Calibration	5-15
3-15 Remote Programming, Constant		5-47 Meter Zero	5-15
Current	3-3	5-49 Ammeter Tracking	5-15
3-24 Remote Programming, Voltage		5-52 Voltmeter Tracking	5-15
Limit	3-4	5-54 Voltage Limit Programming	
3-29 External Voltage Monitoring	3-4	Accuracy and Maximum	
3-31 External AC Modulation	3-5	Output Voltage	5-16
3-35 Special Operating Consider-		5-57 Guard Amplifier Zero	5-16
ations	3-5	5-59 Output Current Zero	5-16
3-36 Pulse Loading	3-5	5-61 Constant Current Remote	
3-38 Reverse Voltage Loading	3-6	Programming Accuracy	5-16
3-40 Reverse Current Loading	3-6		
3-42 Turn-On Transient Protection	3-6		
IV PRINCIPLES OF OPERATION.	4-1	VI REPLACEABLE PARTS	6-1
4-1 Overall Block Diagram Dis-			
cussion	4-1	VII CIRCUIT DIAGRAMS	7-1

SECTION I GENERAL INFORMATION

1-1 DESCRIPTION

1-2 This supply, is designed for applications requiring a constant current source with a high degree of regulation and stability and very low ripple characteristics. The use of a three-position output RANGE switch and a 10-turn output CURRENT control result in resolution down to $0.5\mu\text{A}$. Special attention has been given to circuit details so that well regulated performance is maintained down to very low output currents — of the order of $1\mu\text{A}$.

1-3 A special guard supply, within the unit, provides a voltage which is used to prevent internal leakage currents which would degrade the regulation characteristics. Since the positive output voltage is held equal to the guard voltage, it is also used to drive the front panel voltmeter effectively isolating the voltmeter from the main supply. This prevents the usual output degradation associated with connecting a voltmeter across a constant current supply.

1-4 The supply is completely transistorized (all-silicon) and is suitable for either bench or rack operation. It is of the Constant Current/Voltage Limiting type that will furnish full rated output current at the maximum rated output voltage or can be continuously adjusted throughout the output range. The front panel VOLTAGE control is used to establish the output voltage limit (ceiling) when the supply is used as a constant current source. This control is continuously variable throughout the entire voltage range. The front panel CURRENT control can be used to establish the output current limit (overload or short-circuit) if the supply is used as a voltage-limited source.

1-5 A single meter is used to measure either output voltage or current. The dual selection is accomplished by a METER switch on the front panel. Output current can be measured in one of three ranges in accordance with the RANGE switch setting on the front panel. Output voltage is measured in only one range.

1-6 The power supply has both front and rear terminals. Either the positive or negative output terminal may be grounded or the power supply can be operated floating at up to a maximum of 300 Volts off ground (added safety precautions should be

taken to protect the operator when the supply is used in this mode).

1-7 Terminals at the rear of the unit allow access to various control points within the unit to expand the operating capabilities of the instrument. A brief description of these capabilities is given below:

a. Remote Programming. The power supply can be programmed (controlled) from a remote location by means of an external voltage source or resistance. The output current can be rapidly programmed in the up or down direction using this technique. Remote programming speed is less than 6msec from zero to 99% of maximum rated output with an accuracy of 1%.

b. External Voltage Monitoring. The output voltage of the supply can be externally monitored with an accurate differential or digital voltmeter for applications involving component testing or sorting. Connecting the external meter to the guard voltage prevents output performance degradation when this feature is employed.

c. AC Modulation of Output. An external ac component (or varying dc) can be superimposed on the dc output current of the supply. This feature permits measurement of dynamic impedance, voltage breakdown, and leakage resistance.

1-8 SPECIFICATIONS

1-9 Detailed specifications for the power supply are given in Table 1-1.

1-10 OPTIONS

1-11 Options are factory modifications of a standard instrument that are requested by the customer. The following options are available for the instrument covered by this manual. Where necessary, detailed coverage of the options is included throughout the manual.

<u>Option No.</u>	<u>Description</u>
014	<u>Three Digit Graduated Decadial Current Control</u> : Control that replaces 10-turn current control permitting resettability to within 0.1%.
028	<u>230Vac Operation</u> : Before the supply is shipped from the factory, an internal line voltage selector

switch is set and the proper fuse installed for 230-volt operation. A label on the rear heat sink identifies the line voltage option. (The user can convert an instrument from one line voltage option to the other by following the instructions in Paragraph 2-18.

1-12 ACCESSORIES

1-13 The applicable accessories listed in the following chart may be ordered with the instrument or separately from your local Hewlett-Packard field sales office (refer to list at rear of manual for addresses).

Part No.	Description
5060-8764	Rack Kit for mounting one or two units. (Refer to Section II for details.)
5060-8530	Filler panel to block unused half of rack when mounting only one unit.

1-14 INSTRUMENT IDENTIFICATION

1-15 Hewlett-Packard power supplies are identified by a three-part serial number. The first part is the power supply model number. The second

part is the serial number prefix, consisting of a number-letter combination denoting the date of a significant design change and the country of manufacture. The first two digits indicate the year (10 = 1970, 11 = 1971, etc.); the second two digits indicate the week (01 through 52); and the letter "A", "G", "J", or "U" designates the U. S. A., West Germany, Japan, or the United Kingdom, respectively, as the country of manufacture. The third part is the power supply serial number; a different 5-digit sequential number is assigned to each power supply, starting with 00101.

1-16 If the serial number prefix on your unit does not agree with the prefix on the title page of this manual, change sheets supplied with the manual define the differences between your instrument and the instrument described by this manual.

1-17 ORDERING ADDITIONAL MANUALS

1-18 One manual is shipped with each instrument. Additional manuals may be purchased from your local Hewlett-Packard field office (see list at rear of this manual for addresses). Specify the model number, serial number prefix, and part number provided on the title page.

Table 1-1. Specifications, Models 6177C and 6181C

<p>INPUT: 115Vac $\pm 10\%$, single phase, 48-63Hz, 0.6 amps, 55 watts (nominal)</p> <p>OUTPUT CURRENT RANGES: Model 6177C: 0-500mA, 0-50mA, 0-5mA Model 6181C: 0-250mA, 0-25mA, 0-2.5mA</p> <p>OUTPUT VOLTAGE COMPLIANCE Model 6177C: 50Vdc Model 6181C: 100Vdc (For both models, minimum voltage limit is 0.5 volts)</p> <p>LOAD EFFECT (LOAD REGULATION): The output current changes less than 25ppm of initial value plus 5ppm of current range switch setting for a load change which causes the output voltage to vary from zero to maximum. (The relative humidity must be less than 50% when measuring load effect.)</p> <p>SOURCE EFFECT (LINE REGULATION): The output current changes less than 25ppm of initial value plus 5ppm of range switch setting for any line voltage change within the input rating (104 to 127Vac, or 208 to 254Vac) and at any output current and voltage within rating.</p> <p>RESOLUTION: 0.03% of range switch setting</p>	<p>PARD (RIPPLE AND NOISE):</p> <table border="0"> <tr> <td>Model 6177C: 500mA range</td> <td>160μA/1mA (rms/p-p, dc to 20MHz)</td> </tr> <tr> <td>50mA range</td> <td>16μA/200μA</td> </tr> <tr> <td>5mA range</td> <td>1.6μA/40μA</td> </tr> <tr> <td>Model 6181C: 250mA range</td> <td>80μA/500μA</td> </tr> <tr> <td>25mA range</td> <td>8μA/100μA</td> </tr> <tr> <td>2.5mA range</td> <td>0.8μA/20μA</td> </tr> </table> <p>TEMPERATURE RANGES: Operating: 0 to 40°C ambient. At higher temperatures, maximum output current setting must be reduced linearly to 80% at 55°C. Storage: -40 to 75°C</p> <p>TEMPERATURE COEFFICIENT: Output change per degree Celsius is less than 75ppm of output current plus 5ppm of range switch setting.</p> <p>DRIFT (STABILITY): Total output current drift is less than 100ppm of output plus 25ppm of range switch setting. Drift is measured for 8 hours at constant ambient, line, load, and output setting after an initial warm-up of one hour.</p> <p>LOAD TRANSIENT RECOVERY TIME: Less than 800μsec for output current recovery to within 1% of the nominal output current following a full load change in output voltage.</p>	Model 6177C: 500mA range	160 μ A/1mA (rms/p-p, dc to 20MHz)	50mA range	16 μ A/200 μ A	5mA range	1.6 μ A/40 μ A	Model 6181C: 250mA range	80 μ A/500 μ A	25mA range	8 μ A/100 μ A	2.5mA range	0.8 μ A/20 μ A
Model 6177C: 500mA range	160 μ A/1mA (rms/p-p, dc to 20MHz)												
50mA range	16 μ A/200 μ A												
5mA range	1.6 μ A/40 μ A												
Model 6181C: 250mA range	80 μ A/500 μ A												
25mA range	8 μ A/100 μ A												
2.5mA range	0.8 μ A/20 μ A												

Table 1-1. Specifications, Models 6177C and 6181C (Continued)

<p>PROGRAMMING SPEED: Less than 6 milliseconds are required to program from zero to 99% of the maximum rated output current of each range or from the maximum rated output current of each range to less than 1% of that current.</p> <p>CONSTANT CURRENT REMOTE PROGRAMMING COEFFICIENTS:</p> <p><u>Resistance Programming</u> (Accuracy: 1% of output plus 0.04% of range)</p> <table border="0"> <tr> <td>Model 6177C:</td> <td>500mA range</td> <td>4Ω/mA</td> </tr> <tr> <td></td> <td>50mA range</td> <td>40Ω/mA</td> </tr> <tr> <td></td> <td>5mA range</td> <td>400Ω/mA</td> </tr> <tr> <td>Model 6181C:</td> <td>250mA range</td> <td>20Ω/mA</td> </tr> <tr> <td></td> <td>25mA range</td> <td>200Ω/mA</td> </tr> <tr> <td></td> <td>2.5mA range</td> <td>2000Ω/mA</td> </tr> </table> <p><u>Voltage Programming</u> (Accuracy: 0.5% of output plus 0.04% of range)</p> <table border="0"> <tr> <td>Model 6177C:</td> <td>500mA range</td> <td>2mV/mA</td> </tr> <tr> <td></td> <td>50mA range</td> <td>20mV/mA</td> </tr> <tr> <td></td> <td>5mA range</td> <td>200mV/mA</td> </tr> <tr> <td>Model 6181C:</td> <td>250mA range</td> <td>10mV/mA</td> </tr> <tr> <td></td> <td>25mA range</td> <td>100mV/mA</td> </tr> <tr> <td></td> <td>2.5mA range</td> <td>1V/mA</td> </tr> </table> <p>VOLTAGE LIMIT REMOTE PROGRAMMING COEFFICIENTS: An external resistance of 870Ω per volt in the Model 6177C or 435Ω per volt in the Model 6181C</p>	Model 6177C:	500mA range	4 Ω /mA		50mA range	40 Ω /mA		5mA range	400 Ω /mA	Model 6181C:	250mA range	20 Ω /mA		25mA range	200 Ω /mA		2.5mA range	2000 Ω /mA	Model 6177C:	500mA range	2mV/mA		50mA range	20mV/mA		5mA range	200mV/mA	Model 6181C:	250mA range	10mV/mA		25mA range	100mV/mA		2.5mA range	1V/mA	<p>will program the voltage limit to within $\pm 25\%$ plus 1 volt. A voltage input of 1 volt per volt will program the voltage limit of both models to within 3 volts.</p> <p>METER RANGES: Model 6177C: 600mA, 60mA, 6mA, and 60Vdc Model 6181C: 300mA, 30mA, 3mA, and 120Vdc</p> <p>OUTPUT IMPEDANCE (Typical; R in parallel with C*)</p> <table border="0"> <tr> <td></td> <td>Model 6177C</td> <td></td> </tr> <tr> <td>500mA range</td> <td>R = 3.3MΩ</td> <td>C = 0.05μF</td> </tr> <tr> <td>50mA range</td> <td>33MΩ</td> <td>0.005μF</td> </tr> <tr> <td>5mA range</td> <td>330MΩ</td> <td>500pF</td> </tr> <tr> <td></td> <td>Model 6181C</td> <td></td> </tr> <tr> <td>250mA range</td> <td>13.3MΩ</td> <td>1000pF</td> </tr> <tr> <td>25mA range</td> <td>133MΩ</td> <td>100pF</td> </tr> <tr> <td>2.5mA range</td> <td>1330MΩ</td> <td>10pF</td> </tr> </table> <p>*The formula $Z = R X_C / \sqrt{R^2 + X_C^2}$ can be used for calculations up to 1MHz. Above 1MHz, the output impedance is greater than the formula would indicate.</p> <p>DIMENSIONS: See Figure 2-1</p> <p>WEIGHT: 4.53kg (10 lbs) net; 5.9kg (13 lbs) shipping</p>		Model 6177C		500mA range	R = 3.3M Ω	C = 0.05 μ F	50mA range	33M Ω	0.005 μ F	5mA range	330M Ω	500pF		Model 6181C		250mA range	13.3M Ω	1000pF	25mA range	133M Ω	100pF	2.5mA range	1330M Ω	10pF
Model 6177C:	500mA range	4 Ω /mA																																																											
	50mA range	40 Ω /mA																																																											
	5mA range	400 Ω /mA																																																											
Model 6181C:	250mA range	20 Ω /mA																																																											
	25mA range	200 Ω /mA																																																											
	2.5mA range	2000 Ω /mA																																																											
Model 6177C:	500mA range	2mV/mA																																																											
	50mA range	20mV/mA																																																											
	5mA range	200mV/mA																																																											
Model 6181C:	250mA range	10mV/mA																																																											
	25mA range	100mV/mA																																																											
	2.5mA range	1V/mA																																																											
	Model 6177C																																																												
500mA range	R = 3.3M Ω	C = 0.05 μ F																																																											
50mA range	33M Ω	0.005 μ F																																																											
5mA range	330M Ω	500pF																																																											
	Model 6181C																																																												
250mA range	13.3M Ω	1000pF																																																											
25mA range	133M Ω	100pF																																																											
2.5mA range	1330M Ω	10pF																																																											

SECTION II INSTALLATION

2-1 INITIAL INSPECTION

2-2 Before shipment, this instrument was inspected and found to be free of mechanical and electrical defects. As soon as the instrument is unpacked, inspect for any damage that may have occurred in transit. Save all packing materials until the inspection is completed. If damage is found, file a claim for damage with the shipper. Hewlett-Packard Sales and Service Office should be notified.

2-3 MECHANICAL CHECK

2-4 This check should confirm that there are no broken knobs or connectors, that the cabinet and panel surfaces are free of dents and scratches, and that the meter is not scratched or cracked.

2-5 ELECTRICAL CHECK

2-6 The instrument should be checked against its electrical specifications. Section V includes an "in-cabinet" performance check to verify proper instrument operation.

2-7 INSTALLATION DATA

2-8 The instrument is shipped ready for bench operation. It is necessary only to connect the instrument to a source of power and it is ready for operation.

2-9 LOCATION

2-10 This instrument is air cooled. Sufficient space should be allotted so that a free flow of cooling air can reach the sides and rear of the instrument when it is in operation. It should be used in an area where the ambient temperature does not exceed 40°C.

2-11 OUTLINE DIAGRAM

2-12 Figure 2-1 illustrates the outline shape and dimensions of the 6177C and 6181C supplies.

2-13 RACK MOUNTING

2-14 This instrument may be rack mounted in a standard 19 inch rack panel either alongside a similar unit or by itself. Figure 2-2 shows how both

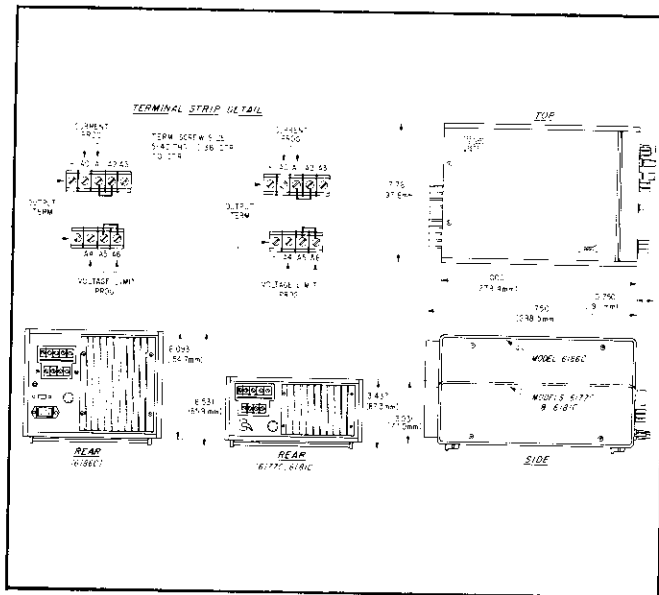

Figure 2-1. Outline Diagram

types of installations are accomplished.

2-15 To mount one, or two units side-by-side, proceed as follows:

- a. Place adaptor frame on bench.
- b. Remove feet from submodular instruments. Place instrument(s) in frame.
- c. Place divider clamps between instruments.
- d. Place divider clamps in position on each end and push the instrument combination into frame.
- e. Insert screws on either side of frame and tighten.

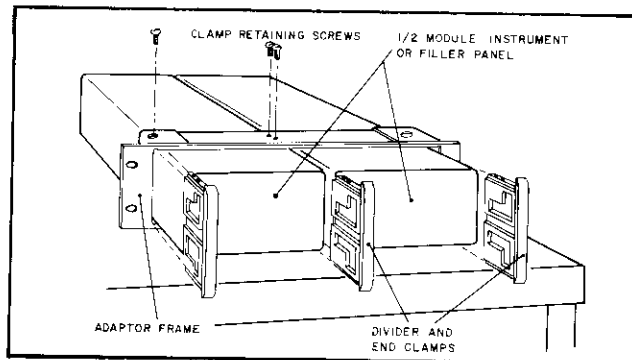

Figure 2-2. Rack Mounting One and Two Units

2-16 INPUT POWER REQUIREMENTS

2-17 A label on the rear of the supply identifies the line voltage option of your supply: 115Vac for the standard instrument, or 230Vac for Option 028 instruments. The input power required at full load is 55 watts; input current is 0.6 amps with a 115Vac input or 0.3 amps with a 230Vac input.

CAUTION

Before applying power to the supply, make certain that its line voltage selector switch (S3) is set for the line voltage to be used. The switch is visible through the perforations in the bottom cover.

2-18 CHANGING THE LINE VOLTAGE OPTION

2-19 If desired, the user can easily convert the unit from 115Vac to 230Vac operation, or vice versa, by following the instructions below.

1. After making certain that the line cord is disconnected from a source of power, remove the bottom cover from the supply. First remove the rear foot by pressing the button and sliding the assembly toward the right side of the supply. Then remove the two screws at the bottom rear and slide the bottom cover to the rear and off. Set the internal switch for the desired input voltage, 115 or 230. Replace the cover.

2. Replace the rear panel ac fuse (F1) with one of the proper rating for the voltage to be used. For 115Vac operation, use a normal time-constant 250V 1-amp fuse (HP Part No. 2110-0001); for 230Vac operation use a normal time-constant 250V 1/2-amp fuse (HP Part No. 2110-0012). The internal dc fuse (F2) does not need to be changed when changing the line voltage option.

3. Mark the instrument clearly with a tag or label indicating the correct line voltage to be used.

2-20 POWER CABLE

2-21 To protect operating personnel, the National Electrical Manufacturers Association (NEMA) recommends that the instrument panel and cabinet be grounded. This instrument is equipped with a three conductor power cable. The third conductor is the ground conductor and when the cable is plugged into an appropriate receptacle, the instrument

is grounded. The offset pin on the power cable three-prong connector is the ground connection. In no event shall this instrument be operated without an adequate cabinet ground connection.

2-22 To preserve the protection feature when operating the instrument from a two-contact outlet, use a three-prong to two-prong adapter (if permitted by local regulations) and connect the green lead on the adapter to ground.

2-23 Model 6177C and 6181C supplies are equipped at the factory with a power cord plug appropriate for the user's location. Figure 2-3 illustrates the standard configurations of power cord plugs used by HP. Above each drawing is the HP option number for that configuration of power connector pins. Below each drawing is the HP part number for a replacement power cord equipped with a plug of that configuration. Notify the nearest HP Sales and Service Office if the appropriate power cord is not included with the instrument.

2-24 REPACKAGING FOR SHIPMENT

2-25 To insure safe shipment of the instrument, it is recommended that the package designed for the instrument be used. The original packaging material is reusable. If it is not available, contact your local Hewlett-Packard field office to obtain the materials. This office will also furnish the address of the nearest service office to which the instrument can be shipped and provide the Authorized Return label necessary to expedite the handling of your instrument return. Be sure to attach a tag to the instrument which specifies the owner, model number, full serial number, and service required, or a brief description of the trouble.

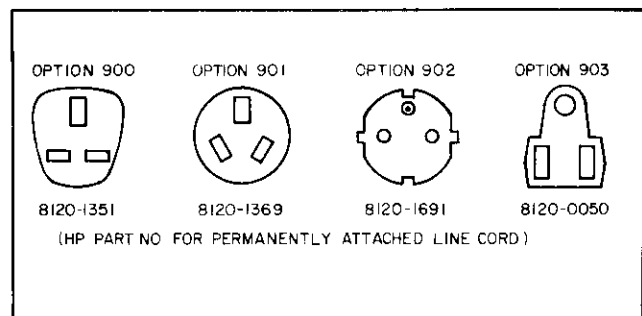

Figure 2-3. Power Cord Configurations

SECTION III OPERATING INSTRUCTIONS

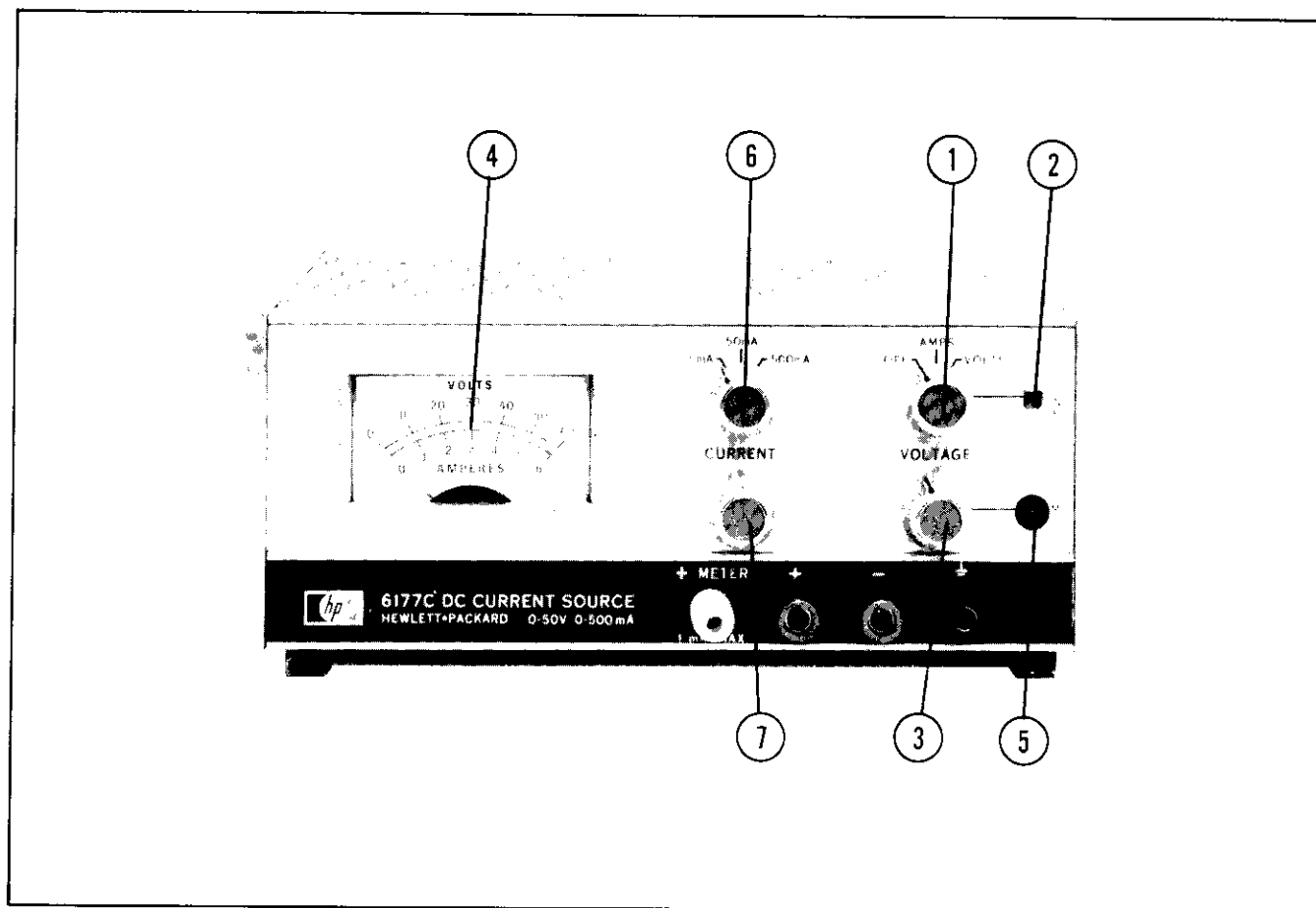

Figure 3-1. Operating Controls and Indicators

3-1 TURN-ON CHECKOUT PROCEDURE

3-2 The following checkout procedure describes the use of the front panel controls and indicators and ensures that the meter and programming circuits are operable. Actual output current should be checked with an external ammeter before connecting delicate loads.

- Set line/meter switch (1) to VOLTS and observe that LINE light (2) goes on.
- To select voltage limit, adjust VOLTAGE control (3) until front panel meter (4) indicates desired output voltage (no load connected).
- VOLTAGE LIMIT lamp (5) should be on with no load connected.
- To select constant current output, turn-off supply and short + and - output terminals (front

or rear).

- Set switch (1) to AMPS and select desired output current range with range switch (6). Adjust CURRENT control (7) for desired output current.

- Remove short and connect load to output terminals (front or rear).

3-3 OPERATING MODES

3-4 The power supply is designed so that its mode of operation can be selected by making strapping connections between particular terminals on the terminal strips at the rear of the power supply. The terminal designations are stenciled in white on the power supply above or below their

respective terminals. The operator can ground either terminal or operate the power supply up to 300Vdc off ground (floating). If one output terminal is to be grounded, the ground connection must be made at the front panel since the rear terminal strips do not contain a ground terminal. The load may be connected to either the front or rear terminals without degrading the performance of the supply in any way.

3-5 The following paragraphs describe the procedures for utilizing the various operational capabilities of the power supply. A more theoretical description concerning the operational features of this supply is contained in Application Note 90, Power Supply Handbook, available at no charge from your local Hewlett-Packard sales office.

3-6 NORMAL OPERATING MODE

3-7 The power supply is normally shipped with its rear terminal strapping connections arranged for Constant Current/Voltage Limiting, local programming, single unit mode of operation. This strapping pattern is illustrated in Figure 3-2. The operator merely selects a constant current output using the front panel controls (local programming, no strapping changes are necessary).

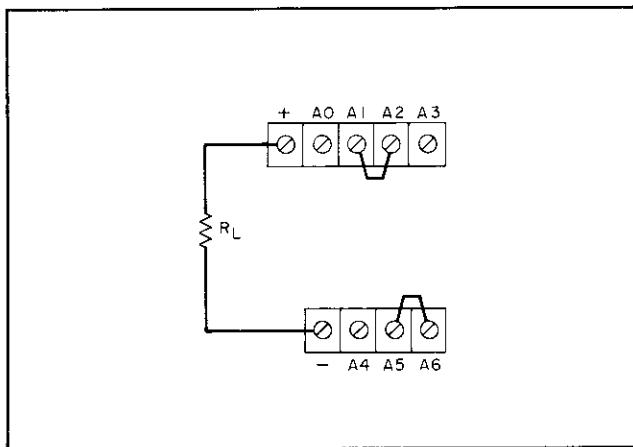

Figure 3-2. Normal Strapping Pattern

3-8 CONSTANT CURRENT

3-9 To select a constant current output, proceed as follows:

- a. With output terminals shorted or open (see NOTE), adjust CURRENT control for desired output current.
- b. With output terminals open, adjust VOLTAGE control for maximum output voltage allowable (voltage limit), as determined by load conditions. If a load change causes the voltage limit to be ex-

ceeded, the power supply will automatically crossover to constant voltage output at the preset voltage limit and the output current will drop proportionately. When this occurs, the VOLTAGE LIMIT lamp on the front panel will light. In setting the voltage limit, allowance must be made for high peak voltages which can cause unwanted crossover. (Refer to Paragraph 3-34.)

NOTE

When the unit is operating in the voltage limit mode (LIMIT lamp on) the front panel ammeter indicates the programmed output current rather than the actual output current. This enables the operator to set the output current (using the front panel CURRENT control) without shorting the output terminals.

3-10 CONNECTING LOAD

3-11 Loads for a constant current source must always be connected in series (never in parallel). If the supply is used as a voltage limited source, the reverse is true — the loads must be connected in parallel. For constant current operation, extreme care must be taken to avoid shunt paths external to the power supply. The presence of shunt paths will tend to degrade the performance of the supply. If the load is remotely located from the supply, shunt paths can be avoided by using shielded cable. If the supply is used as a positive source (negative terminal grounded) one end of the shield can be connected to the guard terminal (designated +METER on the front and terminal A0 on the rear) and the other end left unconnected. This effectively projects the internal guard voltage along the shield affording absolute protection against leakage. If the supply is used as a negative source the above method cannot be utilized. However, the use of a shielded cable will be sufficient to prevent shunt leakage for most applications.

CAUTION

Never connect the negative output terminal to the guard (terminal A0 on the rear). This places a high negative potential at the input of differential amplifiers Q18 and Q19 and will result in damage to these components.

3-12 OPERATION OF SUPPLY BEYOND RATED OUTPUT

3-13 The shaded area on the front panel meter face

indicates the amount of output current or voltage that is available in excess of the rated output. Although the supply can be operated in this shaded region without being damaged, it cannot be guaranteed to meet all of its performance specifications. However, if the line voltage is maintained above 115Vac, the supply will probably operate within its specifications.

3-14 OPTIONAL OPERATING MODES

3-15 REMOTE PROGRAMMING, CONSTANT CURRENT

3-16 Either a resistance or a voltage source can be used to control the constant current output of the supply. The CURRENT control on the front panel is disabled when remote programming the supply.

3-17 Resistance Programming (Figure 3-3). In this mode, the output current varies at a rate determined by the remote resistance programming coefficient. This coefficient is different for each output current range, as shown in Table 1-1 of this manual. The programming coefficient is determined by the constant current programming current which is adjusted to $500 \pm 5\mu\text{A}$ at the factory. If greater programming accuracy is required, it can be achieved by changing resistor R35 as outlined in Section V.

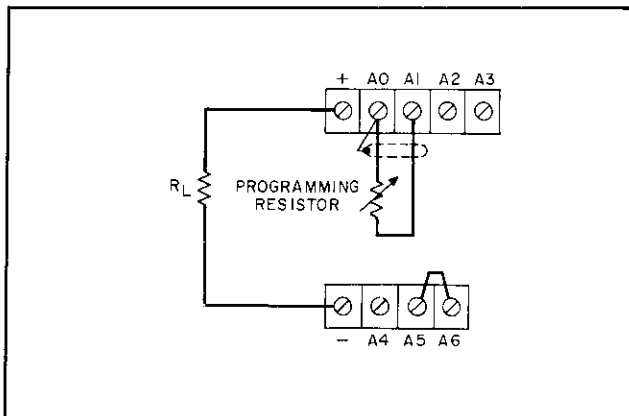

Figure 3-3. Remote Resistance Programming, Constant Current

3-18 Use stable, low noise, low temperature coefficient programming resistors to maintain the power supplies temperature coefficient and stability specifications. A switch may be used to set discrete values of output current. A make-before-break type of switch should be used since the output current will exceed the maximum rating of the power supply if the switch contacts open during the switching interval.

CAUTION

If the programming terminals (A0 and A1) should open at any time in the remote programming mode, the output current will rise to a value that may damage the power supply and/or the load. A protection resistor ($2K\Omega$ Model 6177C or $5K\Omega$ Model 6181C) can be connected across the programming terminals to avoid the possibility; however, note that the addition of the resistor will alter the linear programming coefficient given in Table 1-1.

3-19 If the negative output terminal of the supply is grounded, care must be taken to avoid leakage current paths from the programming source to the negative output terminal (ground). Shunt paths such as this, will seriously degrade the performance of the supply.

3-20 Voltage Programming (Figure 3-4). In this mode, the output current varies at a linear rate determined by the voltage programming coefficient given in Table 1-1. The entire voltage span for the source is approximately 0-1 Volt (Model 6177C) or 0-2.5 Volts (Model 6181C). The programming voltage should never exceed 1.2 Volts (Model 6177C) or 3 Volts (Model 6181C). Voltages in excess of this will result in excessive power dissipation in the instrument and possible damage.

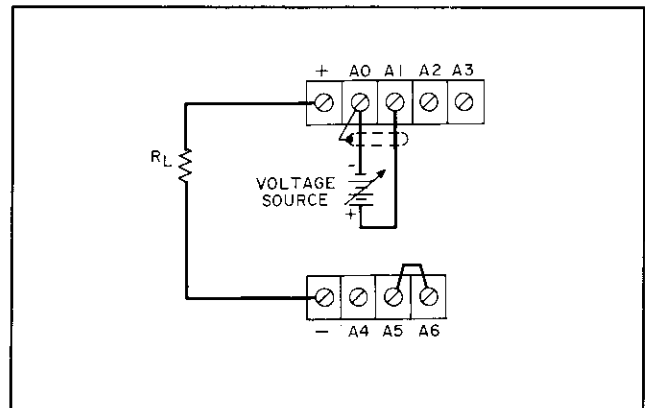

Figure 3-4. Remote Voltage Programming, Constant Current

3-21 The $500\mu\text{A}$ programming current, flowing into terminal A1 from the reference supply (see schematic), imposes two restrictions in the voltage programming mode. The first restriction is that the voltage source must be capable of sinking (absorb-

ing) this 500 μ A current and the second restriction is that, if the programming terminals are opened, the programming current will cause the output current to rise to an excessive level (refer to CAUTION note of Paragraph 3-18). Protection resistors, previously mentioned in the CAUTION note, can be employed to limit the output current to a safe value under any conditions.

3-22 If the user finds that his voltage source cannot sink the 500 μ A programming current, the programming current path to terminal A1 can be opened by removing resistor R37 from the main printed circuit board. This does not detract from the voltage programming performance in any way; but does eliminate the need for sinking the programming current. Opening R37 also obviates the need for an open terminal protection resistor. Opening the programming terminals with no programming current results in zero output current instead of an excessive output current.

3-23 If the negative output terminal of the supply is grounded, the voltage source must be floating (ungrounded). In addition, shunt leakage paths from the floating source to the negative terminal must be avoided. To accomplish this, the case of the voltage source can be connected to the guard terminal (A0) affording complete protection against leakage. If this method is used, ensure that the case is not grounded by any other means; such as the power line.

3-24 REMOTE PROGRAMMING, VOLTAGE LIMIT

3-25 The voltage limit of the supply can be programmed with a remote resistance or voltage source if required. Note that the front panel VOLTAGE control is disconnected by the following procedures.

3-26 Resistance Programming (Figure 3-5). The voltage limit of the supply is determined by the programming coefficient — 870 Ω per Volt for Model 6177C or 435 Ω per Volt for Model 6181C. The voltage programming current is 1.15mA (Model 6177C) or 2.3mA (Model 6181C) and is factory adjusted to within 25%. Adjustment of the programming accuracy can be achieved by changing resistor R6 as described in Section V.

3-27 A switch can be used in conjunction with various resistance values in order to obtain discrete voltages. The switch should have make-before-break contacts to avoid momentarily opening the programming terminals during the switching interval. Opening the programming terminals (A4 and A6) causes the output voltage to rise above normal and may damage the load device.

3-28 Voltage Programming (Figure 3-6). In this

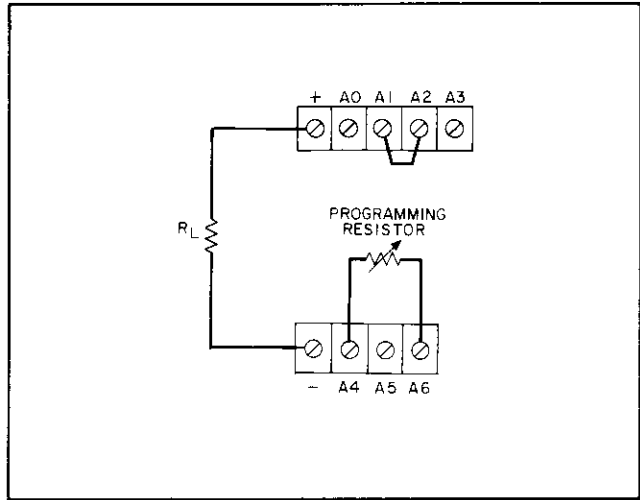

Figure 3-5. Remote Resistance Programming, Voltage Limit

mode, the voltage limit will vary in a 1 to 1 ratio with the programming voltage (voltage source). Similar to voltage programming the output current, Paragraph 3-19, the voltage source used must be capable of sinking the 1.15mA (Model 6177C) or 2.3mA (Model 6181C) programming current flowing into terminal A6. If the users source cannot absorb this current, the programming current path can be opened by disconnecting the collector lead of Q2 (see schematic). This does not adversely affect the operation of the supply in any way.

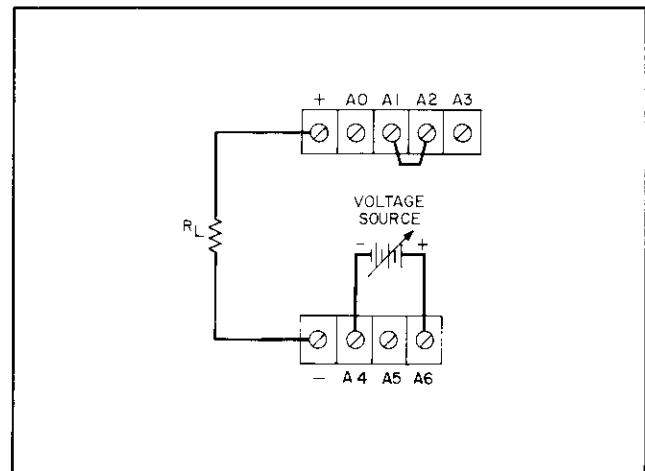

Figure 3-6. Remote Voltage Programming, Voltage Limit

3-29 EXTERNAL VOLTAGE MONITORING

3-30 If accurate indications of output voltage are required, they can be obtained with an external

voltmeter, as shown in Figure 3-7. Notice that one end of the meter is connected to the guard terminal (A0). This effectively isolates the meter from the main power supply, preventing the performance degradation that would occur if the meter were connected directly across the + and - output terminals.

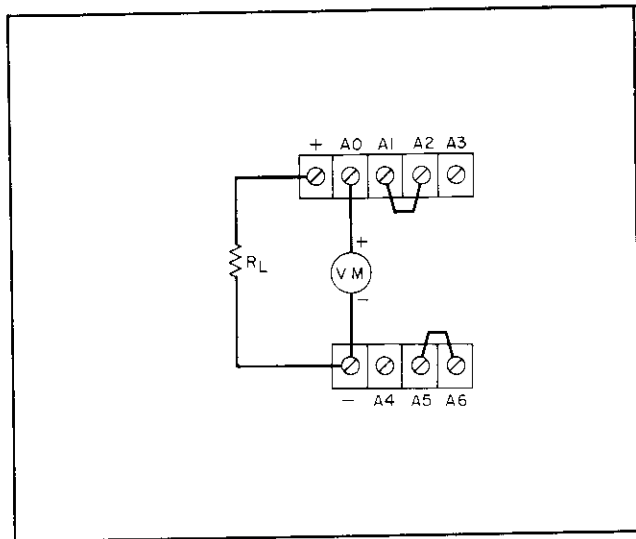

Figure 3-7. External Voltage Monitoring

NOTE

The external voltmeter must not draw more than 1mA from the auxiliary source that provides the guard voltage. A current drain in excess of 1mA will seriously impair the operation of the power supply.

3-31 EXTERNAL AC MODULATION

3-32 Figure 3-8 shows a method of superimposing an ac component on top of the adjustable dc output current of the supply, which is operating as a constant current source. The dc current level is controlled in the normal fashion from the front panel while the ac component of the output current is determined by the modulation percentage. The percentage of modulation is affected by the amplitude of the external voltage input and the value of the series resistance, as follows: % Modulation = $E_{\text{source}} (\text{pk-pk}) / R_X$ (in $K\Omega$). Using the above formula, the user would require an external resistance of $2K\Omega$ and a 2 Volts peak-to-peak input signal from the external source to modulate a dc current level of 100mA by 100%. In this case, the output current would swing between 200mA and zero Am-

peres. The output current should never be allowed to swing beyond the rating of the supply (500mA, p-p, for Model 6177C or 250mA, p-p, for Model 6181C) or clipping of the output and possible internal damage will result.

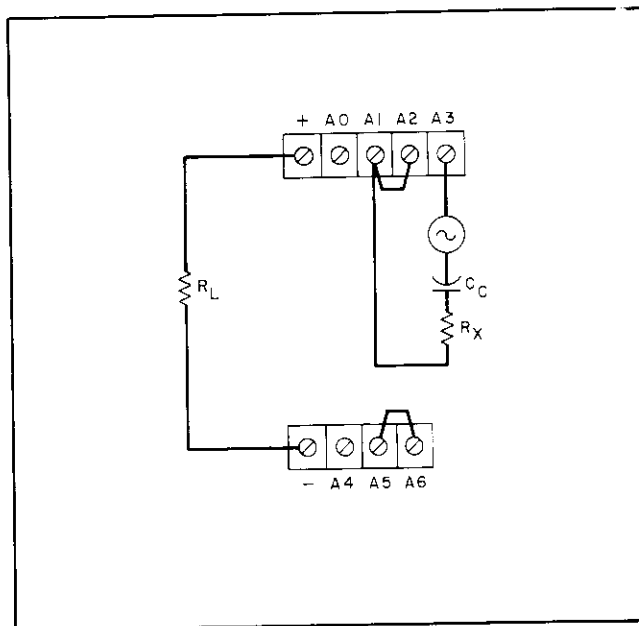

Figure 3-8. External AC Modulation

3-33 The coupling capacitor (C_c) should be chosen so that its reactance is at least ten-times smaller than R_X at the frequency of interest. For input frequencies up to 50Hz the output of the supply can be modulated 100%. Above 50Hz the modulation capability decreases linearly to approximately 10% at 500Hz.

3-34 Notice that it is possible to remotely program the dc output current of the supply in the external modulation mode of operation. This can be accomplished by removing the strap between A1 and A2 and connecting the programming source across these terminals.

3-35 SPECIAL OPERATING CONSIDERATIONS

3-36 PULSE LOADING

3-37 The power supply will automatically cross over from constant current to voltage limiting operation in response to an increase (over the preset limit) in the output voltage. Although the preset limit may be set higher than the average output voltage high peak voltages (as occur in pulse loading) may exceed the preset limit and cause crossover to occur. If this crossover limiting is not desired, set the preset limit for the peak requirement and not the average.

3-38 REVERSE VOLTAGE LOADING

3-39 Diode CR34 is connected internally across the supply. Under normal operating conditions, the diode is reverse biased (anode connected to negative terminal). If a reverse voltage is applied to the output terminals (positive voltage applied to negative terminal), the diode will conduct, shunting current across it. This diode protects the series transistors and drivers.

3-40 REVERSE CURRENT LOADING

3-41 An active load connected to the power supply may actually deliver a reverse current to the power supply during a portion of its operating cycle. An external source cannot be allowed to pump current into the supply without loss of regulation. Diodes CR35, CR36, CR47, and CR48, connected in series with the negative output lead,

protect internal components from damage by blocking these reverse currents. However, to avoid regulation degradation, it is necessary to preload the supply with a dummy load resistor so that the power supply delivers current through the entire operating cycle of the load device.

3-42 TURN-ON TRANSIENT PROTECTION

3-43 Immediately following turn-on, the voltage at the positive output terminal of the supply goes slightly negative (to about -1 volt) for several seconds until the internal reference and bias voltages stabilize. The maximum output current available during this interval is about -15mA. When powering a load that could be damaged by this small negative voltage, connect a diode in series with the load with its anode toward the positive output terminal to block any reverse current. The series diode has no effect on the current regulation characteristics of the supply.

SECTION IV PRINCIPLES OF OPERATION

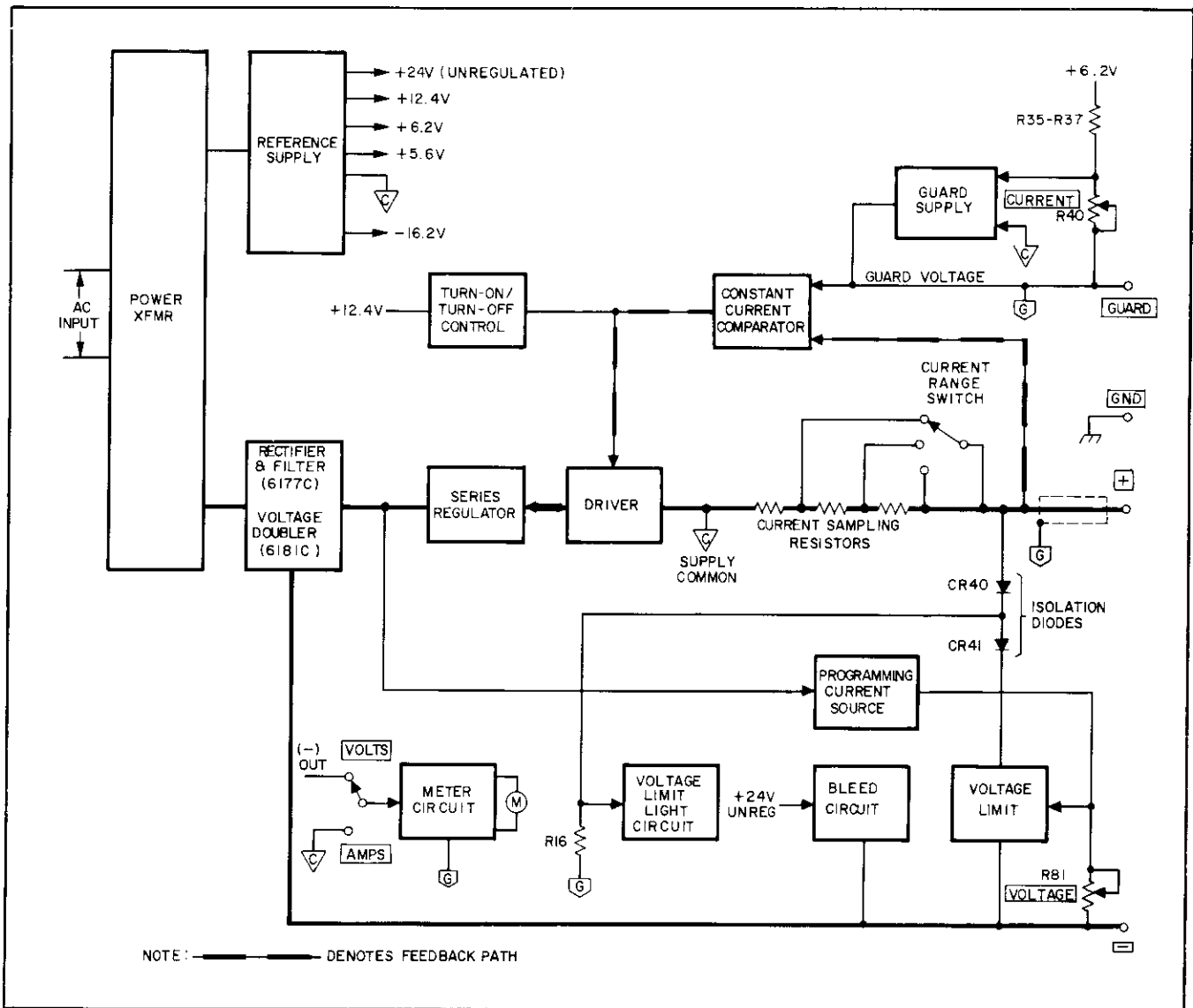

Figure 4-1. Overall Block Diagram

4-1 OVERALL BLOCK DIAGRAM DISCUSSION

4-2 The block diagram of Figure 4-1 shows the major circuits of two DC Current Sources, the Model 6177C and the 6181C. The circuits of these two power supplies are similar except for differing component values and rectifier circuits. The 6177C uses a full-wave bridge rectifier and capacitor filter to produce the unregulated voltage supplied to its current regulating circuits. To produce a higher output voltage, the Model 6181C substitutes a voltage doubler circuit for

the full-wave bridge.

4-3 The output current of the supply is precisely regulated by a transistor circuit connected in series with the rectifier or voltage doubler. The conductance of this series regulator, and thus the output current, is controlled by a negative feedback error signal produced by the constant current comparator and amplified by the driver.

4-4 The constant current comparator is a high gain differential amplifier. The two voltages it compares

are: 1) the voltage drop across some current sampling resistors connected in series with the positive output terminal, and 2) the output voltage of an auxiliary regulated supply called the guard supply.

4-5 The voltage across the current sampling resistors is proportional to the supply's output current. The current range switch on the front panel selects a value of current sampling resistance that produces the same voltage drop at maximum output in each of the supply's output ranges.

4-6 The guard supply is a precision variable voltage supply whose 0 to -1V (6177C) or 0 to -2.5V (6181C) output programs the unit's regulated output current by acting as a reference voltage for the constant current comparator. The guard supply uses the +6.2V output of the reference supply as its reference voltage. The 10-turn current control on the front panel adjusts the output current of the main supply by varying the guard voltage input to the comparator.

4-7 The constant current comparator controls the conductance of the series regulator so that the comparator's two inputs remain equal. This holds the supply output current at the value that produces a voltage drop across the sampling resistors equal to the output of the guard supply. As the ac input voltage fluctuates or the load on the output of the supply changes, any tendency for the output current to change is almost completely canceled as a result of the error signal the comparator produces.

4-8 When the supply is first energized, the turn-on/turn-off control circuit limits the turn-on rate of the series regulator to prevent an output current surge.

4-9 In addition to serving as a reference voltage for the comparator, the guard voltage has two other functions. First, this voltage is used to shield the output conductors within the supply against leakage currents. Second, it allows the output voltage and current of the supply to be metered without affecting the output of the supply. The guard voltage can serve both of these functions because it is always exactly equal to the voltage of the supply's positive output terminal.

4-10 Even small leakage currents that might flow between the output conductors of a regulated supply can be significant because they subtract directly from the output current and thus impair current regulation. This is especially true at low output currents. By surrounding the positive output conductor with a copper conductor which is at guard potential, leakage is minimized because now there is no difference in potential to cause leakage

current to flow. Any leakage that might flow from guard to the negative output does not flow through the current sampling resistors and thus has no effect on current regulation. A front panel guard terminal makes the guard voltage available for extending this technique of shielding against leakage to external load circuits, if required.

4-11 To avoid loading the output, the meter circuit takes advantage of the fact that the guard voltage equals the voltage of the positive output terminal. If a voltmeter were connected directly across the output of the supply, it would draw part of the current that should flow through the load. Connecting the front panel voltmeter between the negative output terminal and guard avoids this problem. An external voltmeter can be connected between the negative output and the front panel guard terminal if an output voltage reading of greater accuracy is required. Since the difference between the guard voltage and supply common is equal to the voltage drop across the current sampling resistors and this drop, in turn, is proportional to the output current, the front panel meter in its current ranges is connected between guard and supply common.

NOTE

The common point for the internal circuits of this supply is at the inboard side of the sampling resistors. This ensures that only output current flows through the sampling resistance. Supply common () must not be used as a ground connection or connected to the positive or negative output terminal.

(The output current meter does not indicate actual load current but instead indicates the output current that has been programmed, whether or not a load is connected across the output.)

4-12 The bleed circuit keeps series regulator current above a minimum value when a small output current is programmed. This is necessary to keep the regulator transistors in their active operating region. Current from the +24V unregulated output of the reference supply circulates through the bleed circuit, the main rectifiers, the series regulator, and the driver, and returns to supply common without flowing through the current sampling resistors.

4-13 The reference supply is an auxiliary voltage supply which provides several voltages, unregulated and regulated, that are required by other

circuits of the supply. The reference supply's +6.2V output is the basic reference voltage for the output current regulator.

4-14 The output voltage of a regulated dc current source depends on the resistance of the load and on the output current that has been programmed. A voltage limit circuit is provided to limit this voltage to an appropriate value such as the maximum safe voltage for the load being powered. The voltage limit circuit consists of a shunt voltage regulator whose output voltage can be programmed to the desired maximum output voltage of the supply. The voltage limit in these supplies can be set to any value from 0.5 volts to the voltage compliance of the supply (50Vdc in the 6177C, or 100Vdc in the 6181C). The programming current source provides a fixed current through the control that sets the voltage limit. Two isolation diodes connect the output of the voltage limit circuit to the output of the current regulator. During normal operation one of these diodes (CR41) is reverse biased and no current flows, but if the supply output exceeds the preset voltage limit, both diodes conduct and the voltage limit circuit draws sufficient current from the current regulator to hold its voltage at the programmed voltage limit. (Whenever the output of the supply has no load connected, all of the programmed current indicated by the front panel meter flows through the isolation diodes and the voltage limit circuit.)

4-15 To minimize leakage through isolation diode CR40 during normal operation, the junction of CR40 and CR41 is connected to guard potential through R16 in the voltage limit light circuit. Diode CR41, then, has as its reverse voltage the entire difference between the programmed voltage limit and the actual output voltage. When voltage limiting occurs, the voltage limit light circuit detects the voltage drop across CR40 and lights a front panel voltage limit indicator.

4-16 DETAILED CIRCUIT DESCRIPTION

4-17 REFERENCE SUPPLY

4-18 The reference supply is a regulated voltage supply that provides stable bias and reference voltages used throughout the instrument. All of the reference supply outputs are derived from the raw dc produced by full-wave rectifier CR5 through CR8 and filter capacitor C3. These voltages are measured with respect to supply common (∇).

4-19 Transistors Q14 and Q15 form a differential amplifier which compares a voltage proportional to that of the +12.4V output to the stable +6.2

volts across the temperature-compensated zener VR5. The error signal produced is amplified by driver Q13 to control the conductance of two parallel series regulator transistors, Q11 and Q12. These series regulator transistors hold the +12.4V output constant.

4-20 The +6.2 volts across VR5 also provides the reference current input to the guard supply. Two more reference supply outputs of +5.6 volts and -16.2 volts are shunt regulated by VR12 and VR6. A +24V unregulated output is taken from the raw dc input to the reference supply.

4-21 GUARD SUPPLY

4-22 The guard supply is a constant voltage regulator whose output is set by current control R40 on the front panel. The output of the guard supply is used as a programming voltage for the constant current comparator. Guard voltage is also used to shield the unit's output conductors and to avoid having to draw meter current from the output of the current regulator.

4-23 The guard supply consists of a differential input stage, Q18, and an integrated circuit output amplifier, U2. Constant current source Q22 biases the input stage. R40 is connected as a feedback resistor between the output of U2 and the amplifier summing point at terminal A1. Because the base of Q18B is tied to supply common, the summing point remains at zero volts. As a result, the programming current through R40 from the +6.2 reference remains constant regardless of R40's resistance setting. The value of R35 is selected to adjust this programming current. (The instrument's output current can be remotely programmed by a resistance or voltage input between terminals A1 and A2. See Section III for remote current programming instructions.)

4-24 The input of the differential amplifier is protected from overvoltage by a limiting network consisting of R39, CR15, and CR16. The collector currents of Q18 are adjusted by R46 to equalize the emitter-base voltages of Q18A and B. Zener diode VR3 is connected across the output of the guard supply to prevent the output from going positive at turnoff or from exceeding -4.3 volts. The normal output range of the guard supply is zero to -1 volt in the 6177C and zero to -2.5 volts in the 6181C. To protect the inputs of the guard supply and the constant current comparator from damage, the series combination of VR3 and CR38 clamps the transients which appear across the output current sampling resistors when the output of the current regulator is shorted.

NOTE

When the output of the guard supply is used to drive an external voltmeter, the maximum current which can be drawn without affecting the performance of the instrument is 1 milliamp.

4-25 CONSTANT CURRENT COMPARATOR

4-26 The constant current comparator is a differential amplifier whose function is to compare the voltage drop across the current sampling resistors to the output voltage of the guard supply and to produce an error signal proportional to this difference. This error signal is amplified by the driver and applied to the series regulator to keep the supply's output current at the desired value.

4-27 The constant current comparator consists of a differential input stage, Q19, a dual emitter follower driver amplifier, Q23 and Q24, and an integrated circuit output amplifier, U1. Constant current source Q21 biases the input stage. (VR10 serves as the voltage reference for both bias current sources, Q21 and Q22.) One side of the differential input is connected to the guard supply while the other is connected to the outboard side of the appropriate current sampling resistor through current range switch S2. R50 protects the inputs of the constant current comparator and the guard supply by limiting the peak current that output transients can inject into them and also acts as a fuse. Jumper J4, connected between the guard supply and the base of Q19B, is intended to be disconnected during some troubleshooting procedures. R46 is another zero balance adjustment. It is set so that the minimum setting of front panel current control R40 corresponds to a zero ampere output current.

4-28 CR13 and VR4 form a voltage limiter which is connected internally through U1-8 to limit the output of U1 at pin 6. When an increasing step change in output current is called for, the output of U1 goes positive, reverse biasing CR30 and allowing the series regulator to turn on. The limiter operates at +4 volts to prevent the output of U1 from charging C28 up to +12 volts and delaying the start of regulation until C28 can discharge again.

4-29 The output of the constant current comparator acts as a variable current sink for the drive current supplied to the series regulator through transistor Q31 in the turn-on/turn-off control circuit.

4-30 DRIVER AND SERIES REGULATOR

4-31 Q26 in the driver circuit, connected as an emitter follower, amplifies the output of the constant current comparator to drive the bases of driver transistors Q27 and Q28. (The turn-on bias for Q26 comes from the turn-on/turn-off control, while the constant current comparator acts as a variable current sink and absorbs the excess current.) Q25 in the series regulator, also connected as an emitter follower, serves as a series-regulating voltage regulator to provide at its emitter a low impedance +5-volt supply which is used as a collector supply by Q26 and as a base bias by output power transistors Q29 and Q30. Q29 and Q30 operate in the grounded base mode and have their emitters driven by Q27 and Q28. About 4.5 volts of the output voltage of the main raw dc supply appears across Q27 and Q28 while the remainder is divided between the load on the output terminals and the parallel combination of Q29 and Q30.

4-32 Diode CR24 is in series with the base of Q26 to protect Q26 against reverse voltage and also to protect U1 from damage in the event of a series regulator failure.

4-33 If a circuit failure occurs that would tend to increase the supply's output voltage uncontrollably, VR14 (in the 6177C) or VR14 and VR15 (in the 6181C) clamp the driver circuit directly and limit the output voltage to 60 volts (or 150 volts) to protect Q6 in the voltage limit circuit from excessive power.

4-34 TURN-ON/TURN-OFF CONTROL

4-35 All turn-on bias for Q26 in the driver circuit passes through Q31 in the turn-on/turn-off control circuit. When ac power is applied to the instrument, this circuit prevents an output current overshoot by delaying the application of turn-on bias to the driver until all bias voltages have stabilized. Q31 remains turned off until C34 charges through R78. Then Q31 turns on the driver.

4-36 When the instrument is deenergized, it is necessary to discharge C34 quickly in order to be prepared for the next time power is applied. Programmable unijunction transistor Q32 discharges C34 when Q32 is fired by the rapid fall in voltage of the +12.4-volt supply.

4-37 VOLTAGE LIMIT PROGRAMMING CURRENT SOURCE

4-38 The voltage limit programming current source

sends a constant current through the front panel voltage limit control, R81. Transistor Q2 compares the voltage drop across its emitter resistors to the fixed 6.2 volts across VR2. The value of voltage limit programming current through R81 is adjusted by selecting the value of R6. The programming current is adjusted to limit the maximum setting of R81 to 110% of the specified compliance of the supply.

4-39 VOLTAGE LIMIT CIRCUIT

4-40 The voltage limit circuit is a three-transistor shunt regulator which limits the power supply's output terminal voltage by shunting output current through CR40, CR41, and Q6 when the output voltage exceeds the voltage limit setting. When the unit is not in voltage limit, Q6 draws enough current through R82 to maintain its collector voltage at about the voltage developed across R81. The shunt regulator's input transistor, Q4, compares the voltage on R81 to the regulator's output voltage and drives Q5, which in turn drives Q6. VR7 protects Q4 from the overvoltage that could be caused if the voltage limit programming leads connected between A5 and A6 were opened. (The instrument's voltage limit setting can be remotely programmed by a resistance or voltage input to terminals A5 and A6. See Section III for remote voltage limit programming instructions.) The voltage developed across CR49 assures that Q5 has sufficient collector voltage. Turn-on bias for Q6 and the operating bias for Q5 is received from the

bleed circuit.

4-41 The voltage drop across CR35, CR36, CR47, and CR48 make the emitter resistor return point of Q6 more negative than the negative output terminal of the supply in order that the output voltage limit can be adjusted to as low as zero volts. R84 maintains a bleed current through these four diodes to maintain this voltage drop when output current is low.

4-42 VOLTAGE LIMIT LIGHT CIRCUIT

4-43 Isolation diode CR40 normally has equal voltages at its anode and cathode: the supply's output at its anode, and guard potential supplied through R16 in the voltage limit light circuit at its cathode. Since the guard and output voltages are always equal, the voltage across R16 equals that across CR40. When voltage limiting occurs and CR40 conducts, the change in voltage across R16 is amplified by U3 and Q8 to light voltage limit light DS2 on the front panel.

4-44 BLEED CIRCUIT

4-45 The bleed circuit is another constant current circuit similar to the voltage limit programming current source. Transistor Q1 uses VR1 as a voltage reference and maintains a relatively constant current through R9. The current path for bleed current is described in paragraph 4-12.

SECTION V MAINTENANCE

5-1 INTRODUCTION

5-2 Upon receipt of the power supply, the performance check (Paragraph 5-5) should be made. This check is suitable for incoming inspection. If a fault is detected in the power supply while making the performance check or during normal operation, proceed to the troubleshooting procedures (Paragraph 5-38). After troubleshooting and repair, perform any necessary adjustments and calibrations (Paragraph 5-45). Before returning the power supply to normal operation,

repeat the performance check to ensure that the fault has been properly corrected and that no other faults exist. Before performing any maintenance checks, turn-on power supply and allow a half-hour warm-up.

5-3 TEST EQUIPMENT REQUIRED

5-4 Table 5-1 lists the test equipment required to perform the various procedures described in this Section.

Table 5-1. Test Equipment Required

TYPE	REQUIRED CHARACTERISTICS	USE	RECOMMENDED MODEL
Differential Voltmeter	Sensitivity: 1mV full scale (min.). Input impedance: 10 megohms (min.). Resolution: 1 ppm of range.	Measure dc voltages; calibration procedures	Ⓜ 3420A/B
Variable Voltage Transformer	Range: 90-130 Volts. Equipped with voltmeter accurate within 1 Volt.	Vary ac input	---
Ac Voltmeter	Accuracy: 2%. Sensitivity: 0.1mV full scale deflection (min.).	Measure ac voltages and rms ripple	Ⓜ 3400A
Oscilloscope	Sensitivity: 100 μ V/cm. Differential input.	Display transient response waveforms	Ⓜ 180A with 1821A time base and 1806A vertical, plus 1801A for noise measurements.
Dc Voltmeter	Accuracy: 1%. Input resistance: 20,000 ohms/Volt (min.).	Measure dc voltages	Ⓜ 412A
Repetitive Load Switch	Rate: 60 - 400Hz, 2 μ sec rise and fall time.	Measure transient response and programming speed	See Figures 5-5 and 5-7
Resistive Loads	Values: See Figure 5-3, 30 Watts.	Power supply load resistors	---
Current Sampling Resistors	Values: See Figure 5-3, 0.5%, 10Watts, 5ppm, 4-Terminal.	Measure current; calibrate meter	R1, R2 and R3; see parts table.

Table 5-1. Test Equipment Required (Continued)

TYPE	REQUIRED CHARACTERISTICS	USE	RECOMMENDED MODEL
Resistor	Value: See Paragraph 5-57. ±0.1%, ½ Watt.	Calibrate programming current	---
Decade Resistance Box	Range: 0-100K. Accuracy: 0.1% plus 1 ohm Make-before-break contacts.	Adjust programming accuracy	---

NOTE

A satisfactory substitute for a differential voltmeter is to arrange a reference voltage source and null detector as shown in Figure 5-1. The reference voltage source is adjusted so that the voltage difference between the supply being measured and the reference voltage will have the required resolution for the measurement being made. The voltage difference will be a function of the null detector that is used. Examples of satisfactory null detectors are: 419A null detector, a dc coupled oscilloscope utilizing differential input, or a 50mV meter movement with a 100 division scale. For the latter, a 2mV change in voltage will result in a meter deflection of four divisions.

CAUTION

Care must be exercised when using an electronic null detector in which one input terminal is grounded to avoid ground loops and circulating currents.

5-5 PERFORMANCE TEST

5-6 The following test can be used as an incoming inspection check and appropriate portions of the test can be repeated either to check the operation of the instrument after repairs or for periodic maintenance tests. The tests are performed using a 115Vac 60Hz, single phase input power source. If the correct result is not obtained for a particular check, do not adjust any controls; proceed to troubleshooting (Paragraph 5-38).

5-7 CONSTANT CURRENT TESTS

5-8 For output current measurements, the current

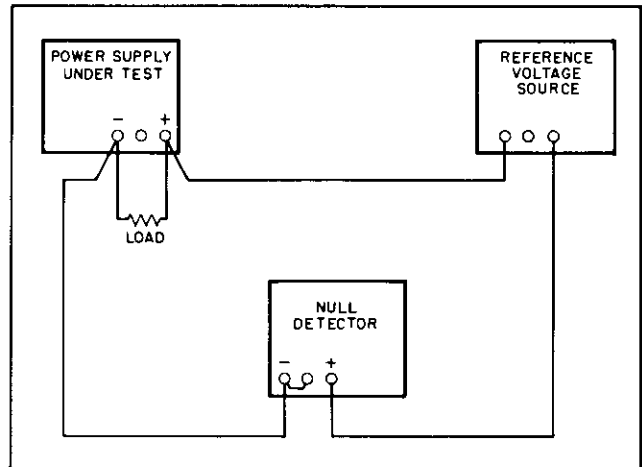

Figure 5-1. Differential Voltmeter, Substitute Test Setup

sampling resistor must be treated as a four terminal device. In the manner of a meter shunt, the load current is fed to the extremes of the wire leading to the resistor while the sampling terminals are located as close as possible to the resistance portion itself (see Figure 5-2). In addition, the resistors should be of the precision, low noise, low temperature coefficient (less than 10ppm/°C) type and should be used at no more than 10% of their rated power so that the temperature rise will be minimized. The latter, reduces resistance

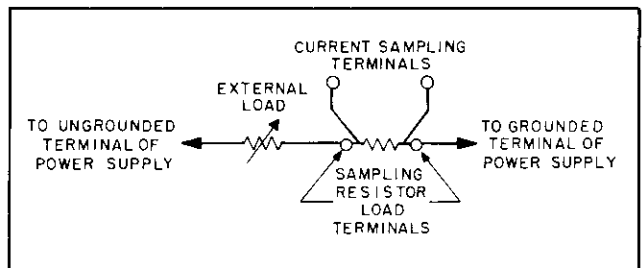

Figure 5-2. Output Current Measurement Technique

changes due to thermal fluctuations. If the user experiences difficulty in obtaining adequate sampling resistors, it is recommended that he obtain duplicates of the sampling resistors (R1, R2, and R3) that are used in the unit.

5-9 The monitoring device is connected across the sampling resistors as shown in Figure 5-3. As indicated in this illustration neither output terminal of the power supply is grounded and the measuring device case is connected to the junction of the load and sampling resistors. This arrangement prevents ground loop paths and shunt current paths. Notice that shunt resistance paths between the external switches and ground can exist. However, since the shunt resistance appears across only one of the external resistors and not across the entire output terminals of the supply, the performance of the supply is not degraded.

5-10 RATED OUTPUT AND METER ACCURACY

5-11 Current. To check the output current for all three ranges, proceed as follows:

- a. Connect test setup shown in Figure 5-3, leaving switch S2 open throughout test.
- b. Turn VOLTAGE control fully clockwise.
- c. Set range switch on front panel to highest current position (500mA Model 6177C, or 250mA Model 6181C).
- d. Set range switch S1 on external test setup to high range and connect + terminal of differential voltmeter to R_{S1}.
- e. Set front panel meter switch to AMPS and adjust CURRENT control until front panel meter indicates exactly the maximum rated output current for this particular range.

f. Differential voltmeter should read as follows:

Model	6177C	6181C
Reading	1 ±0.02Vdc	2.5 ±0.05Vdc

If it does not, refer to adjustment procedure at rear.

- g. To check the medium current range, set the range switches on the front panel and the external test setup to their middle position and differential voltmeter to R_{S2}. Then, repeat Steps e and f. (Readings of Step f apply to every current range.)
- h. To check the low current range, set both range switches to the low current position and repeat Steps e and f.

5-12 Voltage. To check the output voltage proceed as follows:

- a. Connect test setup of Figure 5-3 except connect the differential voltmeter between the guard (terminal A0) and - output terminals (see Figure 3-7 for voltmeter connections).

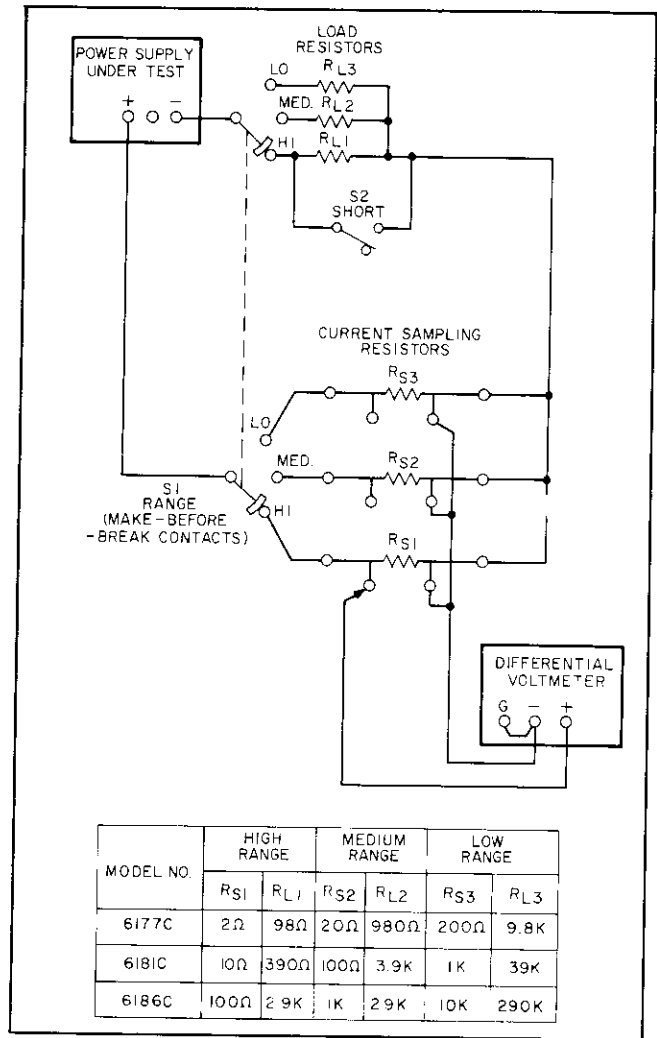

Figure 5-3. Output Current Test Setup

- b. Set range switches to highest current positions and meter switch to VOLTS position.
- c. Turn VOLTAGE control fully clockwise and turn on supply
- d. Adjust CURRENT control until front panel meter indicates exactly the maximum rated output voltage.
- e. Differential voltmeter should indicate the maximum rated output voltage within ±2%. If it does not, refer to adjustment procedure at rear.

5-13 LOAD EFFECT (LOAD REGULATION)

Definition: The change, ΔI_{OUT} in the static value of the dc output current resulting from a change in load resistance from short circuit to a value which yields maximum rated output voltage.

5-14 To check the constant current load regula-

tion for all three output ranges proceed as follows:

- a. Connect test setup shown in Figure 5-3.
- b. Turn VOLTAGE control fully clockwise.
- c. Set internal and external range switches

to highest current positions. Connect + side of differential voltmeter to R_{S1} .

d. Set meter switch to AMPS and adjust CURRENT control until front panel meter reads exactly the maximum rated output current.

e. Read and record voltage indicated on differential voltmeter.

f. Short out load resistor (R_{L1}) by closing switch $S2$.

g. Reading on differential voltmeter should not vary from reading recorded in Step e by more than the following:

Model No.	6177C	6181C
Variation (μ Vdc)	± 30	± 75

h. To check the load regulation for the middle current range, open shorting switch $S2$ and set range switches on front panel and external test setup to their middle position. Connect differential voltmeter to R_{S2} .

i. Next, repeat Steps d through g. Variation should not exceed the reading of Step g.

j. To check the load regulation for the lowest current range, open switch $S2$ and set both range switches to their low current position. Then repeat Steps d through g.

5-15 SOURCE EFFECT (LINE REGULATION)

Definition: The change, ΔI_{OUT} in the static value of dc output current resulting from a change in ac input voltage over the specified range from low line (usually 104 Volts) to high line (usually 127 Volts), or from high line to low line.

5-16 To check the constant current line regulation for all three ranges proceed as follows:

a. Utilize test setup shown in Figure 5-3, except connect variable auto-transformer between input power source and power input to supply. Leave switch $S2$ open throughout test.

b. Turn VOLTAGE control fully clockwise.

c. Set range switches on front panel and external test setup to highest current positions and connect + lead of differential voltmeter to R_{S1} .

d. Set meter switch to AMPS and adjust auto transformer for 104Vac input.

e. Adjust CURRENT control for maximum rated output current on front panel meter.

f. Read and record voltage indicated on differential voltmeter.

g. Adjust auto transformer for 127Vac input.

h. Reading on differential voltmeter should not vary from reading recorded in Step f by more

than the following:

Model No.	6177C	6181C
Variation (μ Vdc)	± 25	± 63

i. To check line regulation for medium current range set both range switches to their middle position and connect differential voltmeter to R_{S2} .

j. Next repeat Steps d through h. Variation should not exceed the reading of Step h.

k. For the lowest current range, set both range switches to the appropriate positions and repeat Steps d through h.

5-17 PARD (RIPPLE AND NOISE)

Definition: The residual ac current which is superimposed on the dc output current of a regulated supply. Ripple and noise may be specified and measured in terms of its RMS or (preferably) peak-to-peak value.

5-18 RMS Measurement. To check the rms ripple and noise, proceed as follows:

a. Use test setup of Figure 5-3, except connect ac voltmeter across sampling resistors instead of differential voltmeter. Ensure that power supply output is floating to avoid ground loops.

NOTE

To prevent extraneous 60Hz pickup, the external range switch and load resistors (R_L and R_S) should be enclosed in a shielded box. Also, the sampling leads connected to the ac meter should be twisted or shielded.

b. Rotate VOLTAGE control fully clockwise.

c. Set range switches to highest current range. Connect + side of ac voltmeter to R_{S1} .

d. Set meter switch to AMPS and adjust CURRENT control until front panel meter indicates exactly the maximum rated output current.

e. The ac voltmeter should read less than the following in the highest current range:

Model No.	6177C	6181C
Reading	320 μ V rms	800 μ V rms

f. To check ripple and noise for the medium and low current ranges, set both range switches to their appropriate positions, and ac voltmeter to appropriate current sampling resistor.

5-19 High Frequency Noise Measurement. When measuring high frequency noise, an oscilloscope of sufficient bandwidth (up to 20MHz) must be

used. Figure 5-4A shows a correct method of measuring the output ripple of a constant current supply using a single-ended scope. Ground loop paths are broken by floating the output terminals of the supply.

5-20 Either a twisted pair or (preferably) a shielded two-wire cable should be used to connect the output terminals of the power supply to the vertical input terminals of the scope. When using shielded two-wire, it is essential for the shield to be connected to ground at one end only so that no ground current will flow through this shield, thus inducing a noise signal in the shielded leads.

5-21 To verify that the oscilloscope is not displaying ripple that is induced in the leads or picked up from the grounds, the (+) scope lead should be shorted to the (-) scope lead at the power supply terminals. The ripple value obtained when the leads are shorted should be subtracted from the actual ripple measurement.

5-22 In most cases, the single-ended scope method of Figure 5-4A will be adequate to eliminate non-real components of ripple and noise so that a satisfactory measurement may be obtained. However, in more stubborn cases, or in measurement situations where it is essential that both the power supply case and the oscilloscope case be connected to ground (e. g. if both are rack-mounted), it may be necessary to use a differential scope with floating input as shown in Figure 5-4B. If desired, two single conductor shielded cables may be substituted in place of the shielded two-wire cable with equal success. Because of its common mode rejection, a differential oscilloscope displays only the difference in signal between its two vertical input terminals, thus ignoring the effects of any common mode signal introduced because of the difference in the ac potential between the power supply case and scope case. Before using a differential input scope in this manner, however, it is imperative that the common mode rejection capability of the scope be verified by shorting together its two input leads at the power supply and observing the trace on the CRT. If this trace is a straight line, the scope is properly ignoring any common mode signal present. If this trace is not a straight line, then the scope is not rejecting the ground signal and must be realigned in accordance with the manufacturer's instructions until proper common mode rejection is attained.

5-23 To check the high frequency noise output, proceed as follows:

- Connect test setup shown in Figure 5-4A or 5-4B.
- Set front panel and external range switches to highest current range.

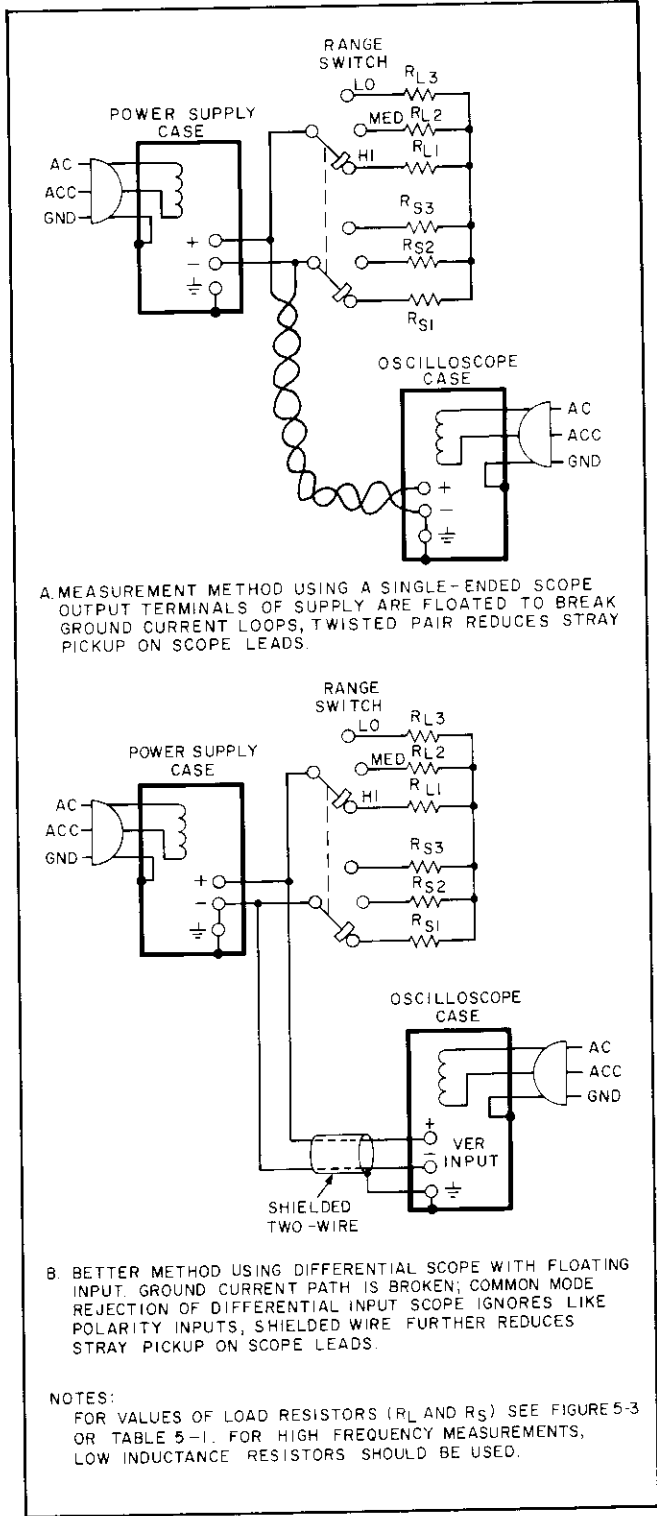

Figure 5-4. High Frequency Ripple and Noise, Test Setup

- Set meter switch to AMPS and adjust CURRENT control for maximum rated output current.
- Observed noise should be less than 2mV

p-p (Model 6177C) or 5mV p-p (Model 6181C).

e. Set range switches to medium range and adjust for rated output current of that range.

f. Observed noise should be less than 4mV p-p (Model 6177C) or 10mV p-p (Model 6181C).

g. Set range switches to lowest range and adjust for rated output current of low range.

h. Observed noise should be less than 8mV p-p (Model 6177C) or 20mV p-p (Model 6181C).

5-24 LOAD TRANSIENT RECOVERY TIME

Definition: The time "X" for output current recovery to within "Y" milliamps of the nominal output current following a "Z" amp step change in load voltage — where:

"Y" is generally of the same order as the load regulation specification. The nominal output current is defined as the dc level half way between the static output current before and after the imposed load change, and "Z" is the specified load voltage change, normally equal to the full load voltage rating of the supply.

5-25 Transient recovery time may be measured at any input line voltage combined with any output voltage and load current within rating.

5-26 Reasonable care must be taken in switching the load resistance on and off. A hand-operated switch in series with the load is not adequate, since the resulting one-shot displays are difficult to observe on most oscilloscopes, and the arc energy occurring during switching action completely masks the display with a noise burst. Transistor load switching devices are expensive if reasonably rapid load current changes are to be achieved.

5-27 A mercury-wetted relay, as connected in the load switching circuit of Figure 5-5 should be used for loading and unloading the supply. When this load switch is connected to a 60Hz ac input, the mercury-wetted relay will open and close 60 times per second. Adjustment of the 25K control permits adjustment of the duty cycle of the load current switching and reduction in jitter of the oscilloscope display.

5-28 To check the load transient recovery time, proceed as follows:

- Connect test setup shown in Figure 5-5.
- Turn VOLTAGE control fully clockwise.
- Set meter switch to AMPS and range switch to highest current range.
- Adjust CURRENT control until front panel meter indicates exactly the maximum rated output current.
- Close line switch on repetitive load switch setup.

f. Adjust 25K potentiometer until a stable display is obtained on oscilloscope. Waveform should be within the tolerances shown in Figure 5-6. Output should return to within $\pm 10\text{mV}$ (Model 6177C) or $\pm 25\text{mV}$ (Model 6181C) of nominal value in less than 800 microseconds.

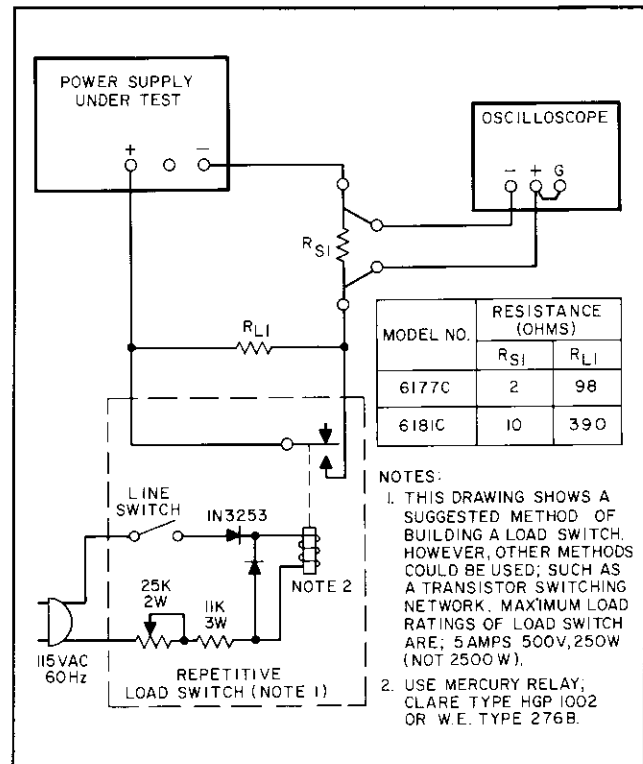

Figure 5-5. Load Transient Recovery Time, Test Setup

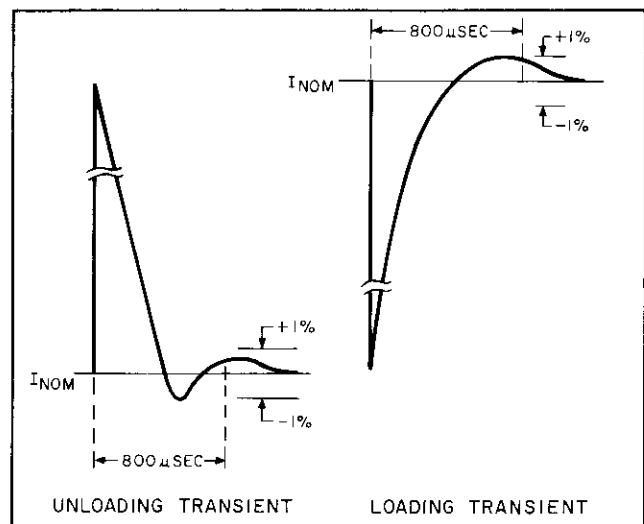

Figure 5-6. Load Transient Recovery Time, Waveforms

5-29 PROGRAMMING SPEED

Definition: The time (msecs) required for the output current to change from zero amps to within "X" milliamps of the maximum rated output, or from maximum rated output to within "X" milliamps of zero. "X" is generally of the same order as the load regulation specification.

5-30 To check the constant current remote programming speed, proceed as follows:

- Connect test setup shown in Figure 5-7.
- Turn VOLTAGE control fully clockwise.
- Set meter switch to AMPS and range switch to highest current range.
- Adjust CURRENT control until front panel meter indicates exactly the maximum rated output current.
- Close line switch for mercury wetted relay and observe waveform on oscilloscope. Rise time indicates up-programming speed and decay time indicates down-programming speed.
- The programming speed should be within the tolerances of Figure 5-8. Output should go from zero to 99 Volts (Model 6177C) or from zero to 49.5 Volts (Model 6181C). Fall time (down programming) should be almost identical to the rise time shown on Figure 5-8 except for inversion.

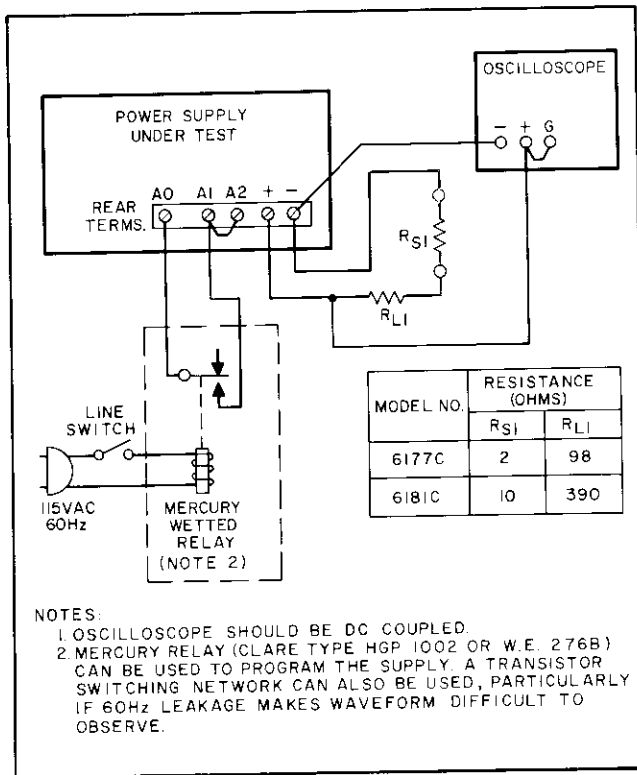

Figure 5-7. Programming Speed, Test Setup

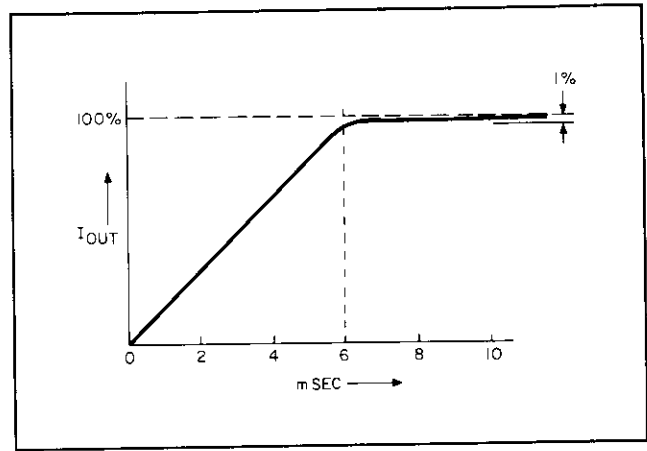

Figure 5-8. Up-Programming Speed Waveform

5-31 OUTPUT STABILITY

Definition: The change in output current for the first 8 hours following a 1-hour warm-up period. During the interval of measurement all parameters such as load resistance, ambient temperature, and input line voltage are held constant.

5-32 The stability of the supply in constant current operation must be measured while holding the temperature of the power supply and the external current sampling resistor (R_S) as constant as possible. A thermometer should be placed near the supply to verify that the ambient temperature remains constant during the measurement period. The supply should be located away from stray air currents; if possible, in an oven which is held at a constant temperature. Variations of the voltage across the current sampling resistor over the specified 8 hour interval are measured on the digital or differential voltmeter and may be recorded on a strip chart recorder. Since such voltage measurements are generally being made at a rather low level, it is important to check that the stability of the measuring instruments is adequate to insure an accurate check on the power supply performance.

5-33 To check the output stability, proceed as follows:

- Connect test setup shown in Figure 5-3.
- Turn VOLTAGE control fully clockwise.
- Set range switches to desired current range and + lead of differential voltmeter to applicable sampling resistor (R_{S1} , R_{S2} or R_{S3}).
- Set METER switch to AMPS and adjust CURRENT control to obtain rated output current.
- Allow one hour warm-up then record differential voltmeter indication.
- After 8 hours, differential voltmeter reading should not change by more than $125\mu\text{Vdc}$

(6177C) or 313 μ Vdc (6181C), in any output current range.

5-34 TEMPERATURE COEFFICIENT

Definition: The change in output current per degree Centigrade change in the ambient temperature under conditions of constant input ac line voltage, output current setting, and load resistance.

5-35 The temperature coefficient of the supply is measured by placing the supply in an oven and varying it over any temperature span within the rating. The current sampling resistor(s), R_S , should not be placed in the oven, but must be held at a constant temperature while this measurement is made.

5-36 The differential voltmeter used to measure the output current change of the supply should be placed outside the oven and should have a long term stability adequate to insure that its drift will not affect the overall measurement accuracy.

5-37 To check the temperature coefficient, proceed as follows:

- a. Connect test setup shown in Figure 5-3.
- b. Turn VOLTAGE control clockwise.
- c. Set range switches to desired current range and connect + lead of differential voltmeter to applicable sampling resistance (R_{S1} , R_{S2} or R_{S3}).
- d. Set METER switch to AMPS and adjust CURRENT control for rated output.
- e. Insert supply into temperature-controlled oven (voltmeter and load resistances remain outside oven). Set temperature to 30°C and allow one hour warm-up.
- f. Record differential voltmeter indication.
- g. Raise oven temperature to 40°C and allow one hour warm-up.
- h. Differential voltmeter indication should change by less than 800 μ Vdc (6177C) or 2mVdc (6181C), in any output current range.

5-38 TROUBLESHOOTING

5-39 Before attempting to troubleshoot this instrument, ensure that the fault is with the instrument and not with an associated circuit. The performance test (Paragraph 5-5) enables this to be determined without having to remove the instrument from the cabinet.

5-40 A good understanding of principles of operation is a helpful aid in troubleshooting, and it is recommended that the reader review Section IV of the manual before attempting to troubleshoot the unit in detail. Once the principles of operation are

understood, refer to the initial troubleshooting procedures in Paragraph 5-43 to locate the symptom and probable cause.

5-41 Section VII of this manual contains a circuit schematic (which applies to both power supply models) and some component location diagrams. Test points on the schematic identified by circled numbers are also indicated on the component location diagrams.

5-42 If a defective component is located, replace it and reconduct the performance test. After the supply is functioning, refer to Table 5-4 to determine if calibration adjustments are required.

5-43 INITIAL TROUBLESHOOTING PROCEDURES

5-44 To locate the cause of trouble, perform the following steps in sequence.

- a. Check for obvious troubles such as an open fuse, a defective power cord, a missing output terminal strap, an improperly positioned line voltage switch, or a defective meter. Output terminal A1 should be strapped to A2 and A5 should be strapped to A6. Do not overlook the dc fuse inside the cabinet. Remove the top and bottom covers and inspect for charred components, open connections, etc. If the trouble source cannot be detected visually, proceed to step (b).

NOTE

While troubleshooting this instrument, keep in mind that the front panel milliammeter does not indicate output current directly, but instead provides a reading proportional to the output voltage of the guard supply. Ordinarily this voltage is proportional to the output current but this cannot be depended on if the instrument is in need of repair. If the front panel milliammeter responds appropriately when the current control is adjusted, the guard supply is functioning. Use an external milliammeter in series with the output to monitor the output current directly while troubleshooting to avoid misinterpreting trouble symptoms.

CAUTION

The RANGE switch must be set for the highest current range at all times while troubleshooting this instrument. Switching to a lower range may cause the destruction of current sampling resistors R2 or R3.

b. Frequently a fault in the reference supply can be misinterpreted as a fault in another circuit. For this reason the reference supply voltages should be checked before attempting to troubleshoot the remainder of the supply's circuits. Measure the voltages in Table 5-2 and check the listed components if any voltages are incorrect. If these components are not at fault, check the circuits that load the reference supply's defective output. (Many possible component failures can affect the voltage of the -16.2V supply. Part of the current that normally flows through VR6 must pass through the bleed current path described in paragraph 4-12. Since this current path includes the series regulator and driver transistors, any fault that cuts off the series regulators will affect this voltage. This is particularly noticeable in the 6181C, where any fault that prevents the series regulators from conducting will reduce the voltage of the -16.2V output to about -10 volts.) If the reference supply voltages are normal or if no output current can be obtained from the power supply and the voltage of the -16.2V reference supply is at least 9 volts, proceed to step (c). The low output of the -16.2V reference will probably be corrected with the guard

supply, main loop, or voltage limit fault that may be causing it.

c. Check whether any of the trouble symptoms listed in Table 5-3 are applicable. If so, follow the instructions provided. If Table 5-3 is not helpful, proceed to step (d).

d. Figure 5-9 is an overall trouble isolation procedure that briefly checks the supply's operation and helps to determine which of three general circuit areas is at fault. These areas are the guard supply, the main feedback loop (which includes the constant current comparator, the turn-on/turn-off control, the driver, and the series regulator), and the voltage limit circuits (including the isolation diodes, the voltage limit programming current source, and the bleed circuit). Because of the many possible interactions among these three circuit areas, it is common for a fault in one of them to hamper attempts to troubleshoot another. Follow the steps of Figure 5-9 exactly as given to isolate these circuits from each other. Figure 5-9 directs the reader to Figures 5-10, 5-11, and 5-12 as necessary to troubleshoot the three circuit areas in detail. Follow all steps in the order they are given.

Table 5-2. Reference Supply Voltages
(Refer to Figure 7-4 Component Location Diagram for Test Point Locations)





METER COMMON	METER POSITIVE	NORMAL VOLTAGE	NORMAL RIPPLE	PROBABLE CAUSE OF TROUBLE
	③	+12.4V ±5%	1mV	VR5, Q11-Q15, C3, C10 CR5-CR8
	④	+6.2V ±5%	100µV	VR5
	⑥	+5.6V ±5%	5µV	VR12, CR10, C35
②		-16.2V ±5%	2mV	VR6, C1 (Also see paragraph 44b)

Table 5-3. Miscellaneous Troubles
(All components are on A2 Main Board Unless Indicated)

SYMPTOM	PROBABLE CAUSE
Output current surge at turn-on or turn-off	Shorted Q31 or open Q32
Output current is limited to less than rated maximum, but supply is not in voltage limit. (Measure <u>actual</u> output current; see note in paragraph 5-44).	a. Shorted CR13, VR4 b. Shorted VR14, VR15
Minimum voltage limit is between 0.5 volts and 3 volts.	Shorted CR35, CR36, CR47, or CR48

Table 5-3. Miscellaneous Troubles (Continued)

SYMPTOM	PROBABLE CAUSE
Voltage limit light will not operate at low output current levels	Shorted isolation diode CR40
LIMIT light not functioning, though output current and voltage limit circuits are normal.	Voltage limit light circuit defective. Check U3 and Q8.
Poor Line Regulation	<ul style="list-style-type: none"> a. Improper measurement technique. Refer to paragraph 5-15. b. Defect in reference supply. Refer to Table 5-2.
Poor Load Regulation	<ul style="list-style-type: none"> a. Improper measurement technique. Refer to paragraph 5-13. b. Defect in reference supply. Refer to Table 5-2. c. The guard supply can be eliminated as a source of trouble by opening jumper J4 and applying a stable external voltage between ∇C and the base of Q19B. Use a 0 to -1V source in the 6177C or a 0 to -2.5V source in the 6181C. d. Dirt on printed circuit board. e. Internal or external leakage path between positive and negative output terminals.
High Ripple	<ul style="list-style-type: none"> a. Improper measurement technique. Refer to paragraph 5-17. b. Defective filter capacitor or rectifier on A1 board c. Ripple in a reference supply output. See Table 5-2.
Oscillation	<ul style="list-style-type: none"> a. Defective capacitor or operational amplifier in guard supply or constant current comparator. As the source of oscillation may be difficult to isolate to one of these areas, the guard supply can be eliminated as described above in (c) under "poor load regulation" and disabled by shorting TP29 to TP31. b. Check C31, C32, C53
Output current or voltage limit not controllable	Guard supply, main feedback loop, or voltage limit circuit defective. Proceed to paragraph 5-44d.

ISOLATION

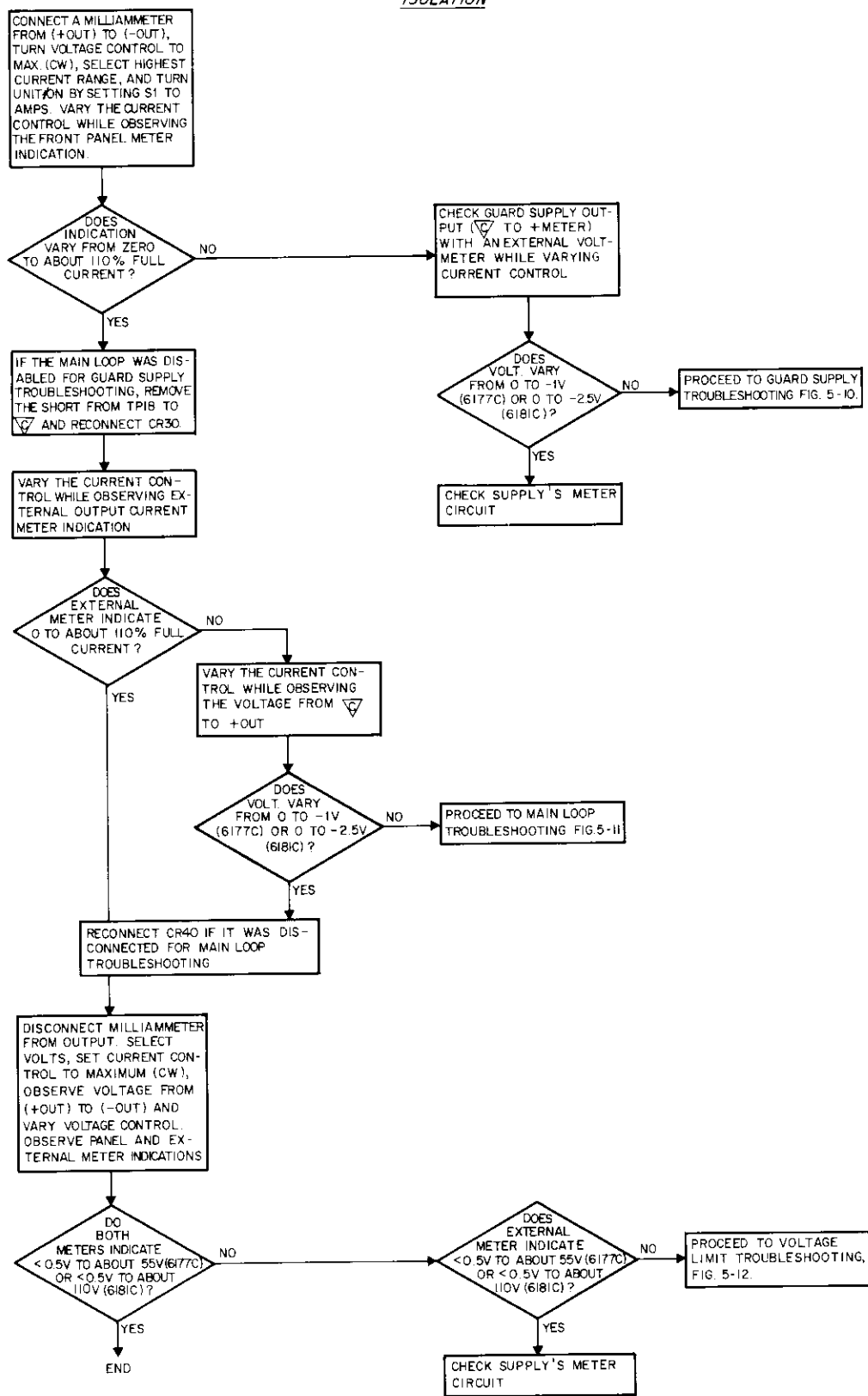

Figure 5-9. Trouble Isolation Procedure

GUARD SUPPLY

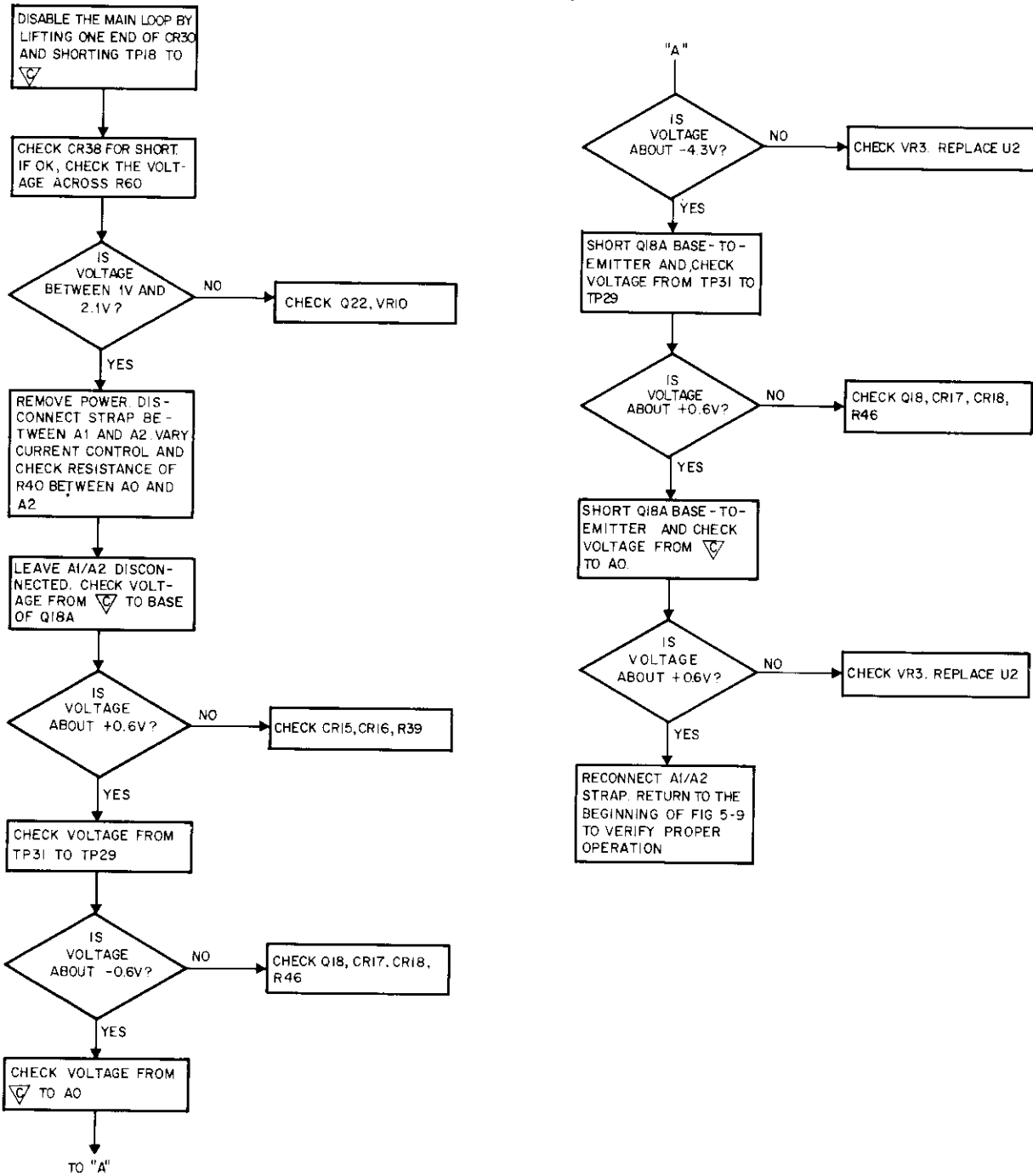

Figure 5-10. Guard Supply Troubleshooting

MAIN LOOP

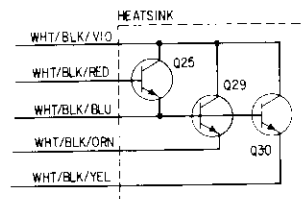
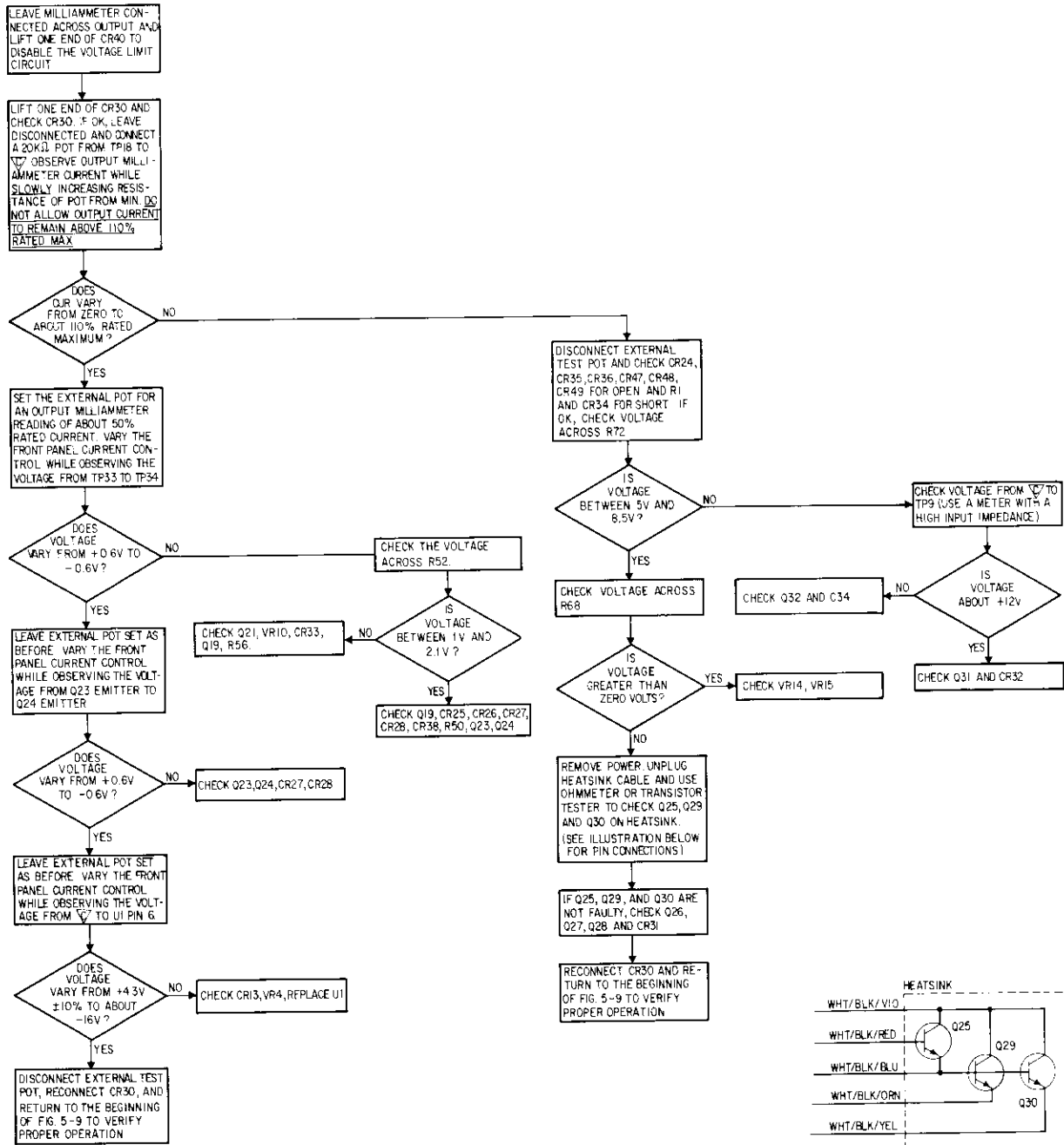

Figure 5-11. Main Loop Troubleshooting

VOLTAGE LIMIT

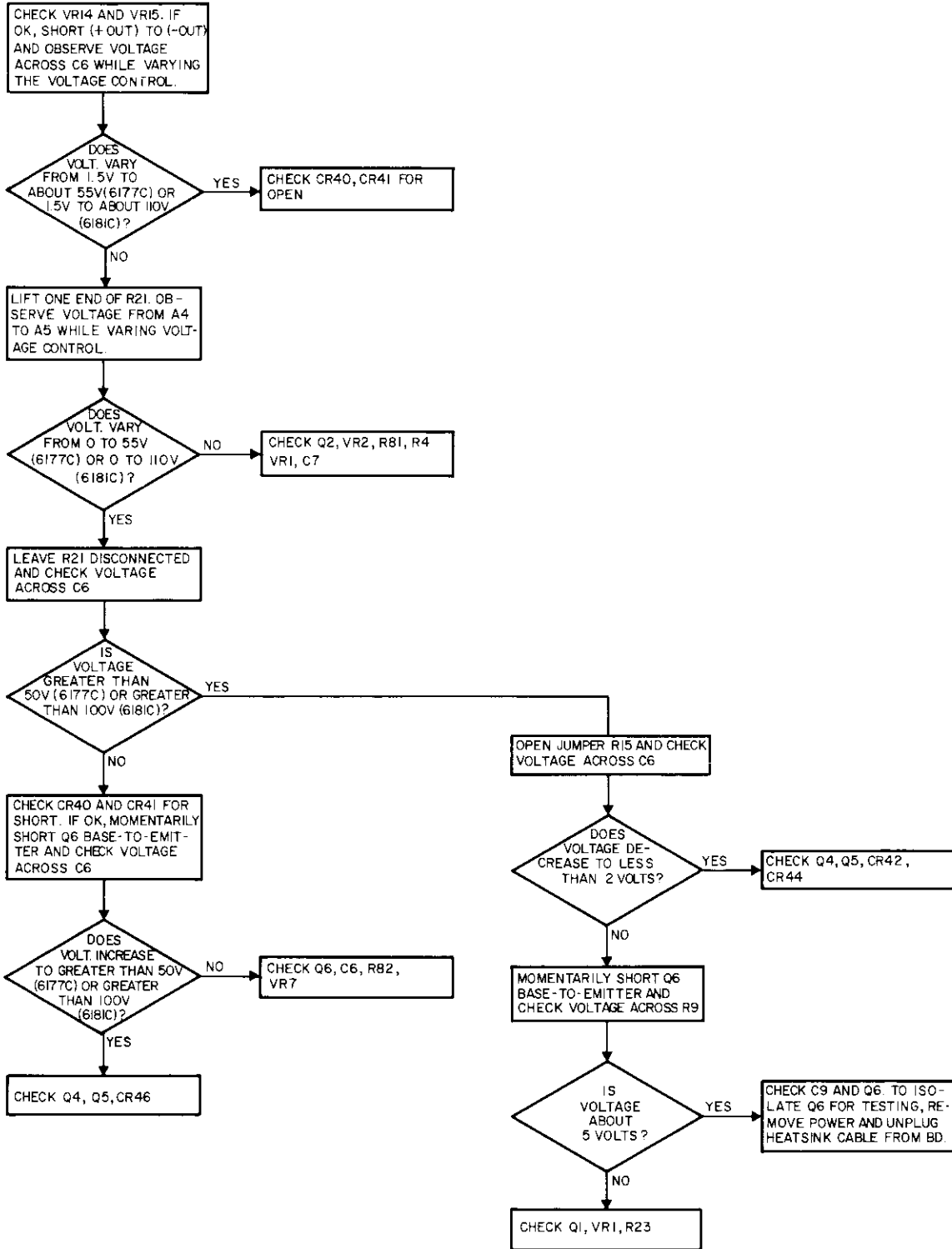

Figure 5-12. Voltage Limit Troubleshooting

Table 5-4. Adjustments Required Following Component Replacement

COMPONENT REPLACED	ADJUSTMENT REQUIRED	ADJUST	ADJUSTMENT PARAGRAPH
VR2 or R81	Voltage limit programming accuracy	R6 (select value)	5-54
Q18	Guard amplifier zero	R46	5-57
Q19	Output current zero	R56	5-59
VR5	Output current programming accuracy	R35 (select value)	5-61

5-45 ADJUSTMENT AND CALIBRATION

5-46 Adjustment and calibration may be required after performance testing, troubleshooting, or repair and replacement. If more than one adjustment must be performed, the sequence of adjustments presented in the following paragraphs should be followed.

5-47 METER ZERO

5-48 Proceed as follows to mechanically zero the meter:

a. Turn off instrument (after it has reached normal operating temperature) and allow 30 seconds for all capacitors to discharge.

b. Insert sharp pointed object (pen point or awl) into the small indentation near top of round black plastic disc located directly below meter face.

c. Rotate plastic disc clockwise (cw) until meter reads zero, then rotate ccw slightly in order to free adjustment screw from meter suspension. If pointer moves, repeat steps (b) and (c).

5-49 AMMETER TRACKING

5-50 The ammeter circuit is adjusted to within $\pm 2\%$, (for full scale readings) at the factory and normally does not require adjustment unless a component in the meter circuit is replaced.

5-51 To calibrate the ammeter, proceed as follows:

a. Replace any meter circuit jumpers (1 or 2; see schematic) that have been removed previously, at the factory.

b. Connect test setup of Figure 5-3 (external range switch and medium-low range load resistors can be eliminated, if desired).

c. Turn VOLTAGE control fully clockwise, set range switch to highest current range, and connect + lead of differential voltmeter to R₅₁.

d. Set meter switch to AMPS and adjust CURRENT control until front panel meter reads exactly the maximum rated output current.

e. Observe reading on differential voltmeter. If it is between 0.981 and 1.019Vdc (Model 6177C) or 2.452 and 2.548Vdc (Model 6181C) leave jumpers 1 and 2 connected and operate normally.

f. If differential voltmeter reading is between 0.941 and 0.981Vdc (Model 6177C) or 2.345 and 2.452Vdc (Model 6181C) remove jumper number 1 (across R89). Reading should now be within normal limits of step (e).

g. If differential voltmeter reading is between 0.905 and 0.941Vdc (Model 6177C) or 2.252 and 2.345Vdc (Model 6181C) remove jumper number 2 (across R90). Reading should now be within normal limits of step (e).

h. If differential voltmeter reading is between 0.865 and 0.905Vdc (Model 6177C or 2.145 and 2.252Vdc (Model 6181C) remove jumpers number one and number two (across R89 and R90). Reading should now be within normal limits of step (e).

5-52 VOLTMETER TRACKING

5-53 The voltmeter is calibrated at the factory, using jumper number 3, and normally does not require adjustment unless the meter is replaced. To calibrate the voltmeter, proceed as follows:

a. Replace jumper number 3 (across R87) if it was previously removed at the factory.

b. Connect test setup of Figure 5-3, except connect differential voltmeter between - and guard (A0) terminals.

c. Turn CURRENT control fully clockwise and set meter switch to VOLTS.

d. Adjust VOLTAGE control until front panel voltmeter reads exactly the maximum rated output voltage.

e. If differential voltmeter reading is above

49Vdc (Model 6177C) or 98.1Vdc (Model 6181C) leave jumper number 3 connected and operate normally. If voltmeter reading is below the above indications, remove jumper number 3. Differential voltmeter indication should now be above the aforementioned reading.

5-54 VOLTAGE LIMIT PROGRAMMING ACCURACY AND MAXIMUM OUTPUT VOLTAGE

5-55 This procedure adjusts the voltage limit programming current to within 20% of 1.15mA (Model 6177C) or 2.3mA (Model 6181C). It allows the unit to provide 110% of the maximum rated output voltage despite a 20% resistance tolerance of the front panel VOLTAGE control. This adjustment is necessary only if the VOLTAGE control (R81) is replaced or it can be done as an accuracy check before remote resistance programming of the voltage limit.

5-56 To adjust the programming current, proceed as follows:

- a. Turn CURRENT and VOLTAGE controls fully clockwise.
- b. Connect differential voltmeter across output terminals of supply (positive output terminal grounded).
- c. Connect decade resistance box in place of R6.
- d. Turn on supply and set meter switch to VOLTS. Adjust decade resistance until differential voltmeter reads 110% of the maximum rated output voltage.
- e. Replace decade resistance with appropriate value resistance in R6 position.

5-57 GUARD AMPLIFIER ZERO

5-58 This adjustment minimizes the offset between the bases of the guard input amplifier, Q18. The offset should be checked and adjusted, if necessary, whenever Q18 is replaced. Proceed as follows to perform this adjustment:

- a. Connect differential voltmeter between rear terminals A1 and A3.
- b. Turn VOLTAGE control fully clockwise.
- c. At any output current, adjust R46 to obtain a $0 \pm 200 \mu\text{Vdc}$ reading on differential voltmeter.

5-59 OUTPUT CURRENT ZERO

5-60 To adjust for zero output current, proceed

as follows:

- a. Connect test setup of Figure 5-3.
- b. Set range switches to highest current range and connect + lead of differential voltmeter to R_{S1} .
- c. Set meter switch to AMPS and turn CURRENT control fully ccw (minimum).
- d. Adjust R56 to obtain reading on differential voltmeter between 0 and $-200 \mu\text{Vdc}$ (Model 6177C) or between 0 and $-500 \mu\text{Vdc}$ (Model 6181C).

5-61 CONSTANT CURRENT REMOTE PROGRAMMING ACCURACY

5-62 This procedure adjusts the constant current programming current within the supply. The programming current is factory set to within 1% and should not need adjustment thereafter unless a sampling resistor or reference supply Zener diode (VR5, VR6) is replaced. The programming accuracy can also be checked and adjusted, if required, before remote resistance programming of the unit.

NOTE

To obtain an accurate adjustment, always zero the output current (refer to preceding paragraph) before making this adjustment.

5-63 To adjust the constant current programming accuracy, proceed as follows:

- a. Connect test setup of Figure 5-3.
- b. Turn VOLTAGE control fully clockwise.
- c. Set both range switches to highest current range and connect + lead of differential voltmeter to R_{S1} .
- d. With supply off, unstrap terminals A1 and A2 and connect precision programming resistor between terminals A0 and A1. Resistor value is $2K\Omega$ (Model 6177C) or $5K\Omega$ (Model 6181C); tolerance must be 0.1% minimum.
- e. Connect decade resistance box in R35 position.
- f. Set meter switch to AMPS and adjust decade box to obtain a reading of $1 \pm 0.01\text{Vdc}$ (Model 6177C) or $2.5 \pm 0.025\text{Vdc}$ (Model 6181C) on differential voltmeter.
- g. Turn off supply and replace decade box with appropriate value resistor in R35 position.

SECTION VI REPLACEABLE PARTS

6-1 INTRODUCTION

6-2 This section contains information for ordering replacement parts. Table 6-4 lists parts in alpha-numeric order by reference designators and provides the following information:

- a. Reference Designators. Refer to Table 6-1.
- b. Description. Refer to Table 6-2 for abbreviations.
- c. Total Quantity (TQ). Given only the first time the part number is listed except in instruments containing many sub-modular assemblies, in which case the TQ appears the first time the part number is listed in each assembly.
- d. Manufacturer's Part Number or Type.
- e. Manufacturer's Federal Supply Code Number. Refer to Table 6-3 for manufacturer's name and address.
- f. Hewlett-Packard Part Number.
- g. Recommended Spare Parts Quantity (RS) for complete maintenance of one instrument during one year of isolated service.
- h. Parts not identified by a reference designator are listed at the end of Table 6-4 under Mechanical and/or Miscellaneous. The former consists of parts belonging to and grouped by individual assemblies; the latter consists of all parts not immediately associated with an assembly.

6-3 ORDERING INFORMATION

6-4 To order a replacement part, address order or inquiry to your local Hewlett-Packard sales office (see lists at rear of this manual for addresses). Specify the following information for each part: Model, complete serial number, and any Option or special modification (J) numbers of the instrument; Hewlett-Packard part number; circuit reference designator; and description. To order a part not listed in Table 6-4, give a complete description of the part, its function, and its location.

Table 6-1. Reference Designators

A = assembly	E = miscellaneous
B = blower (fan)	electronic part
C = capacitor	F = fuse
CB = circuit breaker	J = jack, jumper
CR = diode	K = relay
DS = device, signaling (lamp)	L = inductor
	M = meter

Table 6-1. Reference Designators (Continued)

P = plug	V = vacuum tube, neon bulb, photocell, etc.
Q = transistor	
R = resistor	VR = zener diode
S = switch	X = socket
T = transformer	Z = integrated circuit or network
TB = terminal block	
TS = thermal switch	

Table 6-2. Description Abbreviations

A = ampere	mfr = manufacturer
ac = alternating current	mod. = modular or modified
assy. = assembly	mtg = mounting
bd = board	n = nano = 10^{-9}
bkt = bracket	NC = normally closed
°C = degree Centigrade	NO = normally open
cd = card	NP = nickel-plated
coef = coefficient	Ω = ohm
comp = composition	obd = order by description
CRT = cathode-ray tube	OD = outside diameter
CT = center-tapped	p = pico = 10^{-12}
dc = direct current	P.C. = printed circuit
DPDT = double pole, double throw	pot. = potentiometer
DPST = double pole, single throw	p-p = peak-to-peak
elect = electrolytic	ppm = parts per million
encap = encapsulated	pvr = peak reverse voltage
F = farad	rect = rectifier
°F = degree Fahrenheit	rms = root mean square
fxd = fixed	Si = silicon
Ge = germanium	SPDT = single pole, double throw
H = Henry	SPST = single pole, single throw
Hz = Hertz	SS = small signal
IC = integrated circuit	T = slow-blow
ID = inside diameter	tan. = tantalum
incnd = incandescent	Ti = titanium
k = kilo = 10^3	V = volt
m = milli = 10^{-3}	var = variable
M = mega = 10^6	ww = wirewound
μ = micro = 10^{-6}	W = Watt
met. = metal	

Table 6-3. Code List of Manufacturers

CODE NO.	MANUFACTURER	ADDRESS
00629	EBY Sales Co., Inc.	Jamaica, N. Y.
00656	Aerovox Corp.	New Bedford, Mass.
00853	Sangamo Electric Co. S. Carolina Div.	Pickens, S. C.
01121	Allen Bradley Co.	Milwaukee, Wis.
01255	Litton Industries, Inc.	Beverly Hills, Calif.
01281	TRW Semiconductors, Inc.	Lawndale, Calif.
01295	Texas Instruments, Inc. Semiconductor-Components Div.	Dallas, Texas
01686	RCL Electronics, Inc.	Manchester, N. H.
01930	Amerock Corp.	Rockford, Ill.
02107	Sparta Mfg. Co.	Dover, Ohio
02114	Ferrocube Corp.	Saugerties, N. Y.
02606	Fenwal Laboratories	Morton Grove, Ill.
02660	Amphenol Corp.	Broadview, Ill.
02735	Radio Corp. of America, Solid State and Receiving Tube Div.	Somerville, N. J.
03508	G. E. Semiconductor Products Dept.	Syracuse, N. Y.
03797	Eldema Corp.	Compton, Calif.
03877	Transitron Electronic Corp.	Wakefield, Mass.
03888	Pyrofilm Resistor Co. Inc.	Cedar Knolls, N. J.
04009	Arrow, Hart and Hegeman Electric Co.	Hartford, Conn.
04072	ADC Electronics, Inc.	Harbor City, Calif.
04213	Caddell & Burns Mfg. Co. Inc.	Mineola, N. Y.
04404	*Hewlett-Packard Co. Palo Alto Div.	Palo Alto, Calif.
04713	Motorola Semiconductor Prod. Inc.	Phoenix, Arizona
05277	Westinghouse Electric Corp. Semiconductor Dept.	Youngwood, Pa.
05347	Ultronix, Inc.	Grand Junction, Colo.
05820	Wakefield Engr. Inc.	Wakefield, Mass.
06001	General Elect. Co. Electronic Capacitor & Battery Dept.	Irmo, S. C.
06004	Bassik Div. Stewart-Warner Corp.	Bridgeport, Conn.
06486	IRC Div. of TRW Inc. Semiconductor Plant	Lynn, Mass.
06540	Amatom Electronic Hardware Co. Inc.	New Rochelle, N. Y.
06555	Beede Electrical Instrument Co.	Penacook, N. H.
06666	General Devices Co. Inc.	Indianapolis, Ind.
06751	Semcor Div. Components, Inc.	Phoenix, Arizona
06776	Robinson Nugent, Inc.	New Albany, Ind.
06812	Torrington Mfg. Co., West Div.	Van Nuys, Calif.
07137	Transistor Electronics Corp.	Minneapolis, Minn.

CODE NO.	MANUFACTURER	ADDRESS
07138	Westinghouse Electric Corp. Electronic Tube Div.	Elmira, N. Y.
07263	Fairchild Camera and Instrument Corp. Semiconductor Div.	Mountain View, Calif.
07387	Birtcher Corp., The	Los Angeles, Calif.
07397	Sylvania Electric Prod. Inc. Sylvania Electronic Systems Western Div.	Mountain View, Calif.
07716	IRC Div. of TRW Inc.	Burlington Plant Burlington, Iowa
07910	Continental Device Corp.	Hawthorne, Calif.
07933	Raytheon Co. Components Div. Semiconductor Operation	Mountain View, Calif.
08484	Breeze Corporations, Inc.	Union, N. J.
08530	Reliance Mica Corp.	Brooklyn, N. Y.
08717	Sloan Company, The	Sun Valley, Calif.
08730	Vemaline Products Co. Inc.	Wyckoff, N. J.
08806	General Elect. Co. Minia- ture Lamp Dept.	Cleveland, Ohio
08863	Nylomatic Corp.	Norrisville, Pa.
08919	RCH Supply Co.	Vernon, Calif.
09021	Airco Speer Electronic Components	Bradford, Pa.
09182	*Hewlett-Packard Co. New Jersey Div.	Rockaway, N. J.
09213	General Elect. Co. Semiconductor Prod. Dept.	Buffalo, N. Y.
09214	General Elect. Co. Semiconductor Prod. Dept.	Auburn, N. Y.
09353	C & K Components Inc.	Newton, Mass.
09922	Burndy Corp.	Norwalk, Conn.
11115	Wagner Electric Corp. Tung-Sol Div.	Bloomfield, N. J.
11236	CTS of Berne, Inc.	Berne, Ind.
11237	Chicago Telephone of Cal. Inc.	So. Pasadena, Calif.
11502	IRC Div. of TRW Inc. Boone Plant	Boone, N. C.
11711	General Instrument Corp Rectifier Div.	Newark, N. J.
12136	Philadelphia Handle Co. Inc.	Camden, N. J.
12615	U. S. Terminals, Inc.	Cincinnati, Ohio
12617	Hamlin Inc.	Lake Mills, Wisconsin
12697	Clarostat Mfg. Co. Inc.	Dover, N. H.
13103	Thermalloy Co.	Dallas, Texas
14493	*Hewlett-Packard Co. Loveland Div.	Loveland, Colo.
14655	Cornell-Dubilier Electronics Div. Federal Pacific Electric Co.	Newark, N. J.
14936	General Instrument Corp. Semicon- ductor Prod. Group	Hicksville, N. Y.
15801	Fenwal Elect.	Framingham, Mass.
16299	Corning Glass Works, Electronic Components Div.	Raleigh, N. C.

*Use Code 28480 assigned to Hewlett-Packard Co., Palo Alto, California

Table 6-3. Code List of Manufacturers (Continued)

CODE NO.	MANUFACTURER	ADDRESS
16758	Delco Radio Div. of General Motors Corp.	Kokomo, Ind.
17545	Atlantic Semiconductors, Inc.	Asbury Park, N. J.
17803	Fairchild Camera and Instrument Corp Semiconductor Div. Transducer Plant	Mountain View, Calif.
17870	Daven Div. Thomas A. Edison Industries McGraw-Edison Co.	Orange, N. J.
18324	Signetics Corp.	Sunnyvale, Calif.
19315	Bendix Corp. The Navigation and Control Div.	Teterboro, N. J.
19701	Electra/Midland Corp.	Mineral Wells, Texas
21520	Fansteel Metallurgical Corp.	No. Chicago, Ill.
22229	Union Carbide Corp. Electronics Div.	Mountain View, Calif.
22753	UID Electronics Corp.	Hollywood, Fla.
23936	Pamotor, Inc.	Pampa, Texas
24446	General Electric Co.	Schenectady, N. Y.
24455	General Electric Co. Lamp Div. of Con- sumer Prod. Group	Nela Park, Cleveland, Ohio
24655	General Radio Co.	West Concord, Mass.
24681	LTV Electrosystems Inc Memcor/Com- ponents Operations	Huntington, Ind.
26982	Dynacool Mfg. Co. Inc.	Saugerties, N. Y.
27014	National Semiconductor Corp.	Santa Clara, Calif.
28480	Hewlett-Packard Co.	Palo Alto, Calif.
28520	Heyman Mfg. Co.	Kenilworth, N. J.
28875	IMC Magnetics Corp.	New Hampshire Div. Rochester, N. H.
31514	SAE Advance Packaging, Inc.	Santa Ana, Calif.
31827	Budwig Mfg. Co.	Ramona, Calif.
33173	G. E. Co. Tube Dept.	Owensboro, Ky.
35434	Lectrohm, Inc.	Chicago, Ill.
37942	P. R. Mallory & Co. Inc.	Indianapolis, Ind.
42190	Muter Co.	Chicago, Ill.
43334	New Departure-Hyatt Bearings Div.	General Motors Corp. Sandusky, Ohio
44655	Ohmite Manufacturing Co.	Skokie, Ill.
46384	Penn Engr. and Mfg. Corp.	Doylestown, Pa.
47904	Polaroid Corp.	Cambridge, Mass.
49956	Raytheon Co.	Lexington, Mass.
55026	Simpson Electric Co. Div. of American Gage and Machine Co.	Chicago, Ill.
56289	Sprague Electric Co.	North Adams, Mass.
58474	Superior Electric Co.	Bristol, Conn.
58849	Syntron Div. of FMC Corp.	Homer City, Pa.
59730	Thomas and Betts Co.	Philadelphia, Pa.
61637	Union Carbide Corp.	New York, N. Y.
63743	Ward Leonard Electric Co.	Mt. Vernon, N. Y.

CODE NO.	MANUFACTURER	ADDRESS
70563	Amperite Co. Inc.	Union City, N. J.
70901	Beemer Engrg. Co.	Fort Washington, Pa.
70903	Belden Corp.	Chicago, Ill.
71218	Bud Radio, Inc.	Willoughby, Ohio
71279	Cambridge Thermionic Corp.	Cambridge, Mass.
71400	Bussmann Mfg. Div. of McGraw & Edison Co.	St. Louis, Mo.
71450	CTS Corp.	Elkhart, Ind.
71468	I. T. T. Cannon Electric Inc.	Los Angeles, Calif.
71590	Globe-Union Inc.	Centralab Div. Milwaukee, Wis.
71700	General Cable Corp. Cornish Wire Co. Div.	Williamstown, Mass.
71707	Coto Coil Co. Inc.	Providence, R. I.
71744	Chicago Miniature Lamp Works	Chicago, Ill.
71785	Cinch Mfg. Co. and Howard B. Jones Div.	Chicago, Ill.
71984	Dow Corning Corp.	Midland, Mich.
72136	Electro Motive Mfg. Co. Inc.	Willimantic, Conn.
72619	Dialight Corp.	Brooklyn, N. Y.
72699	General Instrument Corp.	Newark, N. J.
72765	Drake Mfg. Co.	Harwood Heights, Ill.
72962	Elastic Stop Nut Div. of Amerace Esna Corp.	Union, N. J.
72982	Erie Technological Products Inc.	Erie, Pa.
73096	Hart Mfg. Co.	Hartford, Conn.
73138	Beckman Instruments Inc.	Helipot Div. Fullerton, Calif.
73168	Fenwal, Inc.	Ashland, Mass.
73293	Hughes Aircraft Co. Electron Dynamics Div.	Torrance, Calif.
73445	Amperex Electronic Corp.	Hicksville, N. Y.
73506	Bradley Semiconductor Corp.	New Haven, Conn.
73559	Carling Electric, Inc.	Hartford, Conn.
73734	Federal Screw Products, Inc.	Chicago, Ill.
74193	Heinemann Electric Co.	Trenton, N. J.
74545	Hubbell Harvey Inc.	Bridgeport, Conn.
74868	Amphenol Corp. Amphenol RF Div.	Danbury, Conn.
74970	E. F. Johnson Co.	Waseca, Minn.
75042	IRC Div. of TRW, Inc.	Philadelphia, Pa.
75183	*Howard B. Jones Div. of Cinch Mfg. Corp.	New York, N. Y.
75376	Kurz and Kasch, Inc.	Dayton, Ohio
75382	Kilka Electric Corp.	Mt. Vernon, N. Y.
75915	Littlefuse, Inc.	Des Plaines, Ill.
76381	Minnesota Mining and Mfg. Co.	St. Paul, Minn.
76385	Minor Rubber Co. Inc.	Bloomfield, N. J.
76487	James Millen Mfg. Co. Inc.	Malden, Mass.
76493	J. W. Miller Co.	Compton, Calif.

*Use Code 71785 assigned to Cinch Mfg. Co., Chicago, Ill.

Table 6-3. Code List of Manufacturers (Continued)

CODE NO.	MANUFACTURER	ADDRESS
76530	Cinch	City of Industry, Calif.
76854	Oak Mfg. Co. Div. of Oak	
	Electro/Netics Corp.	Crystal Lake, Ill.
77068	Bendix Corp., Electro-dynamics Div.	
		No. Hollywood, Calif.
77122	Palnut Co.	Mountainside, N.J.
77147	Patton-MacGuyer Co.	Providence, R.I.
77221	Phaotron Instrument and Electronic Co.	
		South Pasadena, Calif.
77252	Philadelphia Steel and Wire Corp.	
		Philadelphia, Pa.
77342	American Machine and Foundry Co.	
	Potter and Brumfield Div.	Princeton, Ind.
77630	TRW Electronic Components Div.	
		Camden, N.J.
77764	Resistance Products Co.	Harrisburg, Pa.
78189	Illinois Tool Works Inc. Shakeproof Div.	
		Elgin, Ill.
78452	Everlock Chicago, Inc.	Chicago, Ill.
78488	Stackpole Carbon Co.	St. Marys, Pa.
78526	Stanwyck Winding Div. San Fernando	
	Electric Mfg. Co. Inc.	Newburgh, N.Y.
78553	Tinnerman Products, Inc.	Cleveland, Ohio
78584	Stewart Stamping Corp.	Yonkers, N.Y.
79136	Waldes Kohinoor, Inc.	L. I. C., N.Y.
79307	Whitehead Metals Inc.	New York, N.Y.
79727	Continental-Wirt Electronics Corp.	
		Philadelphia, Pa.
79963	Zierick Mfg. Co.	Mt. Kisco, N.Y.
80031	Mepco Div. of Sessions Clock Co.	
		Morristown, N.J.
80294	Bourms, Inc.	Riverside, Calif.
81042	Howard Industries Div. of Msl Ind. Inc.	
		Racine, Wisc.
81073	Grayhill, Inc.	La Grange, Ill.
81483	International Rectifier Corp.	
		El Segundo, Calif.
81751	Columbus Electronics Corp.	Yonkers, N.Y.
82099	Goodyear Sundries & Mechanical Co. Inc.	
		New York, N.Y.
82142	Airco Speer Electronic Components	
		Du Bois, Pa.
82219	Sylvania Electric Products Inc.	
	Electronic Tube Div. Receiving	
	Tube Operations	Emporium, Pa.
82389	Switchcraft, Inc.	Chicago, Ill.
82647	Metals and Controls Inc. Control	
	Products Group	Attleboro, Mass.
82866	Research Products Corp.	Madison, Wis.
82877	Rotron Inc.	Woodstock, N.Y.
82893	Vector Electronic Co.	Glendale, Calif.
83058	Carr Fastener Co.	Cambridge, Mass.
83186	Victory Engineering Corp.	
		Springfield, N.J.
83298	Bendix Corp. Electric Power Div.	
		Fatontown, N.J.
83330	Herman H. Smith, Inc.	Brooklyn, N.Y.
83385	Central Screw Co.	Chicago, Ill.
83501	Gavitt Wire and Cable Div. of	
	Amerace Esna Corp.	Brookfield, Mass.

CODE NO.	MANUFACTURER	ADDRESS
83508	Grant Pulley and Hardware Co.	
		West Nyack, N.Y.
83594	Burroughs Corp. Electronic	
	Components Div.	Plainfield, N.J.
83835	U. S. Radium Corp.	Morristown, N.J.
83877	Yardeny Laboratories, Inc.	
		New York, N.Y.
84171	Arco Electronics, Inc.	Great Neck, N.Y.
84411	TRW Capacitor Div.	Ogallala, Neb.
86684	RCA Corp. Electronic Components	
		Harrison, N.J.
86838	Rummel Fibre Co.	Newark, N.J.
87034	Marco & Oak Industries a Div. of Oak	
	Electro/netics Corp.	Anaheim, Calif.
87216	Philco Corp. Lansdale Div.	Lansdale, Pa.
87585	Stockwell Rubber Co. Inc.	
		Philadelphia, Pa.
87929	Tower-Olschan Corp.	Bridgeport, Conn.
88140	Cutler-Hammer Inc. Power Distribution	
	and Control Div. Lincoln Plant	
		Lincoln, Ill.
88245	Litton Precision Products Inc, USECO	
	Div. Litton Industries	Van Nuys, Calif.
90634	Gulton Industries Inc.	Metuchen, N.J.
90763	United-Car Inc.	Chicago, Ill.
91345	Miller Dial and Nameplate Co.	
		El Monte, Calif.
91418	Radio Materials Co.	Chicago, Ill.
91506	Augat, Inc.	Attleboro, Mass.
91637	Dale Electronics, Inc.	Columbus, Neb.
91662	Elco Corp.	Willow Grove, Pa.
91929	Honeywell Inc. Div. Micro Switch	
		Freeport, Ill.
92825	Whitso, Inc.	Schiller Pk., Ill.
93332	Sylvania Electric Prod. Inc. Semi-	
	conductor Prod. Div.	Woburn, Mass.
93410	Essex Wire Corp. Stemco	
	Controls Div.	Mansfield, Ohio
94144	Raytheon Co. Components Div.	
	Ind. Components Oper.	Quincy, Mass.
94154	Wagner Electric Corp.	
	Tung-Sol Div.	Livingston, N.J.
94222	Southco Inc.	Lester, Pa.
95263	Loecraft Mfg. Co. Inc.	L. I. C., N.Y.
95354	Methode Mfg. Co.	Rolling Meadows, Ill.
95712	Bendix Corp. Microwave	
	Devices Div.	Franklin, Ind.
95987	Weckesser Co. Inc.	Chicago, Ill.
96791	Amphenol Corp. Ampnenol	
	Controls Div.	Janesville, Wis.
97464	Industrial Retaining Ring Co.	
		Irvington, N.J.
97702	IMC Magnetics Corp. Eastern Div.	
		Westbury, N.Y.
98291	Sealectro Corp.	Mamaroneck, N.Y.
98410	ETC Inc.	Cleveland, Ohio
98978	International Electronic Research Corp.	
		Burbank, Calif.
99934	Renbrandt, Inc.	Boston, Mass.

Table 6-4. Replaceable Parts

REF. DESIG.	DESCRIPTION	TQ*	MFR. PART NO.	MFR. CODE	HP PART NO.	RS*
A1	<u>Input Board</u>					
C1-3	fxd, elect 400 μ F 100V	3	D40713-DFP	56289	0180-1887	1
C4-6	fxd, cer .05 μ F 400V	4/3	33C17A3-CDH	56289	0150-0052	1
C7						
6177C	fxd, cer .05 μ F 400V		33C17A3-CDH	56289	0150-0052	
6181C	(not used)					
CR1, 2	Diode, 1A 200V	8/6	A14B	03508	1901-0327	2
CR3, 4						
6177C	Diode, 1A 200V		A14B	03508	1901-0327	
6181C	(not used)					
CR5-8	Diode, 1A 200V		A14B	03508	1901-0327	
F2						
6177C	Fuse 1A 250V	1	312001	75915	2110-0001	5
6181C	Fuse 0.5A 250V	1	312.500	75915	2110-0012	5
A2	<u>Main Board</u>					
C1	fxd, elect 20 μ F 50V	1	30D206G050CC2	56289	0180-0049	1
C5	fxd, mica .001 100V	1	D15C1E102J	53021	0160-0938	1
C6	fxd, elect 16 μ F 150V	1	30D166G150DF2	56289	0180-0238	1
C7	fxd, cer .05 400V	1	33C17A3-CDH	56289	0150-0052	1
C8	fxd, mica 470pF 300V	1/2	obd	72136	0140-0149	1
C9	fxd, cer .22 μ F 50V	1	5C52B-CML	56289	0160-0263	1
C10	fxd, elect 68 μ F 15V	1	150D686X0015R2	56289	0180-1835	1
C12	fxd, mica .002 μ F 100V	2	obd	72136	0160-2301	1
C13						
6177C	fxd, cer .01 μ F 1KV	1	C023A102J103MS38	56289	0150-0012	1
6181C	fxd, cer .01 μ F 500V	1	811-000 Y5U 0 103Z	72982	0150-0081	1
C19	fxd, mylar .022 μ F 200V	1	AE17C223KT	06001	0160-0162	1
C20	fxd, cer 0.1 50V	6	5C50B1-CML	56289	0150-0121	1
C21	fxd, mica 18pF 300V	2	obd	72136	0160-0356	1
C22	fxd, cer 0.1 μ F 50V		5C50B1-CML	56289	0150-0121	
C23	fxd, mica .002 μ F 100V		obd	72136	0160-2301	
C24, 25	fxd, cer 0.1 50V		5C50B1-CML	56289	0150-0121	
C26	fxd, mica 18pF 300V		obd	72136	0160-0356	
C27	fxd, cer 0.1 μ F 50V		5C50B1-CML	56289	0150-0121	
C28						
6177C	fxd, mylar 0.1 μ F 200V	1	AE22C104KT	06001	0160-0168	1
6181C	fxd, mylar 0.22 μ F 80V	1	AE22C224KT	06001	0160-2453	1
C29	fxd, cer 0.1 50V		5C50B1-CML	56289	0150-0121	
C31						
6177C	fxd, mica 560pF 300V	1	obd	72136	0140-0178	1
6181C	fxd, mica 470pF 300V		obd	72136	0140-0149	
C32	fxd, mylar .047 200V	1	AE17C473JT	06001	0160-0138	1
C34	fxd, elect 10 μ F 20V	1	150D106X9020B2	56289	0180-0374	1
C35	fxd, elect 1.0 μ F 35V	1	150D105X9035A2	56289	0180-0291	1
C53						
6177C	fxd, mica 750pF 300V	1	obd	72136	0160-2215	1
6181C	fxd, mica 390pF 300V	1	obd	72136	0140-0200	1
CR10	Diode 200mA 180V	11	SG3396	03877	1901-0033	7
CR13	Diode, switching 200mA 80V	1	FDH 6308	07263	1901-0050	1
CR14	Diode, stabistor 150mA 15V	3	STB523	03508	1901-0460	3
CR15, 16	Diode, switching 50mA 75V	4	DA2050	03508	1901-0642	4

*6177C/6181C

Table 6-4. Replaceable Parts

REF. DESIG.	DESCRIPTION	TQ*	MFR. PART NO.	MFR. CODE	HP PART NO.	RS*
CR17, 18, 24	Diode, 200mA 180V		SG3396	03877	1901-0033	
CR25, 26	Diode, switching 50mA 75V		DA2050	03508	1901-0642	
CR27, 28, 30, 31	Diode, 200mA 180V		SG3396	03877	1901-0033	
CR32	Diode, stabistor 150mA 15V		STB523	03508	1901-0460	
CR33	Diode, 200mA 180V		SG3396	03877	1901-0033	
CR34-36, 38, 40, 41	Diode, 1A 200V	9	A14B	03508	1901-0327	6
CR42	Diode, 200mA 180V		SG3396	03877	1901-0033	
CR44	Diode, stabistor 150mA 15V		STB523	03508	1901-0460	
CR46	Diode, 200mA 180V		SG3396	03877	1901-0033	
CR47-49	Diode, 1A 200V		A14B	03508	1901-0327	
L1	Inductor, ferrite bead (Q2 emitter)	1	56-590-65/4A6	02114	9170-0894	1
Q1	SS NPN Si.	1	2N4240	28480	1854-0311	1
Q2, 4	SS PNP Si.	2	40250	02735	1853-0224	2
Q5	SS PNP Si.	1	TZ173	56289	1853-0099	1
Q8	SS NPN Si.	1/3	2N1711A	28480	1854-0244	1/3
Q11, 12	SS PNP Si.	2	2N4036	28480	1853-0041	2
Q13-15	SS NPN Si.	7	2N3391	28480	1854-0071	6
Q18, 19	SS NPN Si. dual	2	2N4045	28480	1854-0221	2
Q21-24	SS NPN Si.		2N3391	28480	1854-0071	
Q26	SS NPN Si.	1	2N3417**	28480	1854-0087	1
Q27, 28						
6177C	SS NPN Si.	2	(See note p. 6-11)	28480	1854-0448	2
6181C	SS NPN Si.		2N1711A	28480	1854-0244	
Q31	SS NPN Si.	1	2N3390**	28480	1854-0202	1
Q32	Programmable unijunction transistor	1	(See note p. 6-11)	28480	1855-0346	1
R1						
6177C	fxd, ww 2 1/2% 7.5W	1	R2067-2	01686	0811-3306	1
6181C	fxd, ww 10 1/2% 7.5W	1	R2067-3	01686	0811-2110	1
R2						
6177C	fxd, ww 18 0.1% 1/8W	1	R2179-3	01686	0811-2777	1
6181C	fxd, ww 90 0.1% 1/8W	1	R2179-2	01686	0811-2779	1
R3						
6177C	fxd, ww 180 0.1% 1/8W	1	R2179-1	01686	0811-2778	1
6181C	fxd, ww 900 1/2% 3/8W	1	R2066-2	01686	0811-2112	1
R4						
6177C	fxd, met ox. 8.2K 5% 2W	1	Type RG42	11502	0764-0044	1
6181C	fxd, comp 33K 5% 2W	1	HB3335	01121	0692-3335	1
R5						
6177C	fxd, film 7.5K 1% 1/8W	1	Type MF4C-1	19701	0757-0440	1
6181C	fxd, film 3.32K 1% 1/8W	1	Type MF4C-1	19701	0757-0433	1
R6	fxd, comp (selected)	1	obd			
R7						
6177C	fxd, comp 300 5% 1/2W	1	EB3015	01121	0686-3015	1
6181C	fxd, comp 2K 5% 1/2W	4	EB2025	01121	0686-2025	1
R9						
6177C	fxd, comp 100 5% 1/2W	7	EB1015	01121	0686-1015	2
6181C	fxd, comp 220 5% 1/2W	1	EB2215	01121	0686-2215	1
R10						
6177C	fxd, ww 6.8K 5% 3W	1	Type 242E	56289	0811-0960	1
6181C	fxd, ww 20K 3% 3W	1	RS2B-95	91637	0811-1337	1

**Transistor leads must be bent properly

Table 6-4. Replaceable Parts

REF. DESIG.	DESCRIPTION	TQ*	MFR. PART NO.	MFR. CODE	HP PART NO.	RS*
R16, 17	fxd, comp 240 5% 1/2W	2/3	EB2415	01121	0686-2415	1
R18	fxd, comp 12K 5% 1/2W	1	EB1235	01121	0686-1235	1
R19	fxd, comp 2K 5% 1/2W	2/	EB2025	01121	0686-2025	1
R20	fxd, comp 1.5K 5% 1W	1	GB1525	01121	0689-1525	1
R21						
6177C	fxd, comp 1K 5% 1/2W	3	EB1025	01121	0686-1025	1
6181C	fxd, comp 2K 5% 1/2W		EB2025	01121	0686-2025	
R22						
6177C	fxd, comp 150 5% 1/2W	1	EB1515	01121	0686-1515	1
6181C	fxd, comp 300 5% 1/2W	1	EB3015	01121	0686-3015	1
R23						
6177C	fxd, ww 0.33 5% 2W	1	Type BWH	75042	0812-0066	1
6181C	fxd, ww 1.0 5% 2W	1	Type BWH	75042	0811-1666	1
R25	fxd, comp 2K 5% 1/2W		EB2025	01121	0686-2025	
R26, 27	fxd, comp 51 5% 1/2W	2	EB5105	01121	0686-5105	1
R28	fxd, comp 20K 5% 1/2W	1	EB2035	01121	0686-2035	1
R29, 30	fxd, film 1.5K 1% 1/8W	2	Type MF4C-1	19701	0757-0427	1
R31	fxd, comp 1.8K 5% 1/2W	1	EB1825	01121	0686-1825	1
R32	fxd, comp 2.7K 5% 1/2W	1	EB2725	01121	0686-2725	1
R33	fxd, comp 5.6K 5% 1/2W	2	EB5625	01121	0686-5625	1
R34	fxd, film 750 1% 1/8W	2/1	Type MF4C-1	19701	0757-0420	1
R35	fxd, film (selected)	1	obd			
R36	fxd, film 118K 1% 1/8W	1	Type MF4C-1	19701	0698-3265	1
R37	fxd, ww 11.8K 1% 1/8W	1	135F	20940	0811-2789	1
R38	fxd, met ox. 430 5% 2W	1	Type RG42	11502	0764-0024	1
R39	fxd, film 100 1% 1/8W	2	Type MF4C-1	19701	0757-0401	1
R41	fxd, comp 100 5% 1/2W		EB1015	01121	0686-1015	
R42, 43	fxd, film 23K 1% 1/8W	2	Type MF4C-1	19701	0698-3269	1
R44	fxd, comp 100 5% 1/2W		EB1015	01121	0686-1015	
R45	fxd, film 64K 1% 1/8W	4	CMF-55-1, T-9	91637	0698-6275	1
R46	var, ww 15K	2	CT-100-4	84048	2100-0896	1
R47	fxd, film 64K 1% 1/8W		CMF-55-1, T-9	91637	0698-6275	
R48	fxd, comp 100 5% 1/2W		EB1015	01121	0686-1015	
R49	fxd, comp 1K 5% 1/2W	/2	EB1025	01121	0686-1025	1
R50	fxd, film 100 1% 1/8W		Type MF4C-1	19701	0757-0401	
R52	fxd, film 10K 1% 1/8W	4	Type MF4C-1	19701	0757-0442	1
R53						
6177C	fxd, comp 470 5% 1/2W	1	EB4715	01121	0686-4715	1
6181C	fxd, comp 240 5% 1/2W		EB2415	01121	0686-2415	
R54	fxd, comp 100 5% 1/2W		EB1015	01121	0686-1015	
R55	fxd, film 64K 1% 1/8W		CMF-55-1, T-9	91637	0698-6275	
R56	var, ww 15K		CT-100-4	84048	2100-0896	
R57	fxd, film 64K 1% 1/8W		CMF-55-1, T-9	91637	0698-6275	
R58	fxd, comp 100 5% 1/2W		EB1015	01121	0686-1015	
R60	fxd, film 10K 1% 1/8W		Type MF4C-1	19701	0757-0442	
R61	fxd, comp 1.3K 5% 1/2W	1	EB1325	01121	0686-1325	1
R62, 63	fxd, film 10K 1% 1/8W		Type MF4C-1	19701	0757-0442	
R64	fxd, film 5.6K 5% 1/4W	1	CB5625	01121	0683-5625	1
R66	fxd, comp 33 5% 1/2W	1	EB3305	01121	0686-3305	1
R67						
6177C	fxd, film 6.2K 5% 1/4W	1	CB6225	01121	0683-6225	1
6181C	fxd, film 9.1K 5% 1/4W	1	CB9125	01121	0683-9125	1
R68	fxd, comp 5.6K 5% 1/2W		EB5625	01121	0686-5625	
R69	fxd, comp 100 5% 1/2W		EB1015	01121	0686-1015	
R70	fxd, comp 360 5% 1/2W	1	EB3615	01121	0686-3615	1

Table 6-4. Replaceable Parts

REF. DESIG.	DESCRIPTION	TQ*	MFR. PART NO.	MFR. CODE	HP PART NO.	RS*
R71	fxd, comp 1K 5% 1/2W		EB1025	01121	0686-1025	
R72	fxd, comp 9.1K 5% 1/2W	1	EB9125	01121	0686-9125	1
R73	fxd, comp 750 5% 1/2W	1	EB7515	01121	0686-7515	1
R74, 75						
6177C	fxd, comp 4.7 5% 1/2W	2	EB47G5	01121	0698-0001	1
6181C	fxd, comp 12 5% 1/2W	2	EB1205	01121	0686-1205	1
R76, 77						
6177C	fxd, comp 3.9 5% 1/2W	2	EB39G5	01121	0698-5139	1
6181C	fxd, comp 8.2 5% 1/2W	2	EB82G5	01121	0698-5479	1
R78	fxd, film 330K 5% 1/4W	1	CB3345	01121	0683-3345	1
R79	fxd, film 18 5% 1/4W	1	CB1805	01121	0683-1805	1
R80						
6177C	fxd, ww 2K 5% 5W	1	Type 5XM	14841	0812-0100	1
6181C	fxd, ww 5K 5% 5W	1	Type 5XM	14841	0812-0060	1
R82						
6177C	fxd, ww 5K 5% 5W	1	Type 5XM	14841	0812-0060	1
6181C	fxd, ww 15K 5% 5W	1	Type 5XM	14841	0811-1867	1
R83	fxd, film 10K 5% 1/4W	1	CB1035	01121	0683-1035	1
R84						
6177C	fxd, ww 7.5K 5% 3W	1	Type 242E	56289	0811-1815	1
6181C	fxd, met ox. 33K 5% 2W	1	Type RG42	11502	0764-0046	1
R85						
6177C	fxd, film 750 1% 1/8W		Type MF4C-1	19701	0757-0420	
6181C	fxd, film 2.37K 1% 1/8W	1	Type MF4C-1	19701	0698-3150	1
R86						
6177C	fxd, film 330 1% 1/8W	1	Type MF4C-1	19701	0698-5663	1
6181C	fxd, film 909 1% 1/8W	1	Type MF4C-1	19701	0757-0422	1
R87						
6177C	fxd, film 42.2K 1% 1/8W	1	Type MF4C-1	19701	0698-3450	1
6181C	fxd, film 105K 1% 1/4W	1	CMF-60-1, T-1	91637	0698-4757	1
R88						
6177C	fxd, comp 1.5M 5% 1/2W	1	EB1555	01121	0686-1555	1
6181C	fxd, comp 3.3M 5% 1/2W	1	EB3355	01121	0686-3355	1
R89						
6177C	fxd, comp 16 5% 1/2W	1	EB1605	01121	0698-3561	1
6181C	fxd, comp 39 5% 1/2W	1	EB3905	01121	0686-3905	1
R90						
6177C	fxd, comp 27 5% 1/2W	1	EB2705	01121	0686-2705	1
6181C	fxd, comp 68 5% 1/2W	1	EB6805	01121	0686-6805	1
R91	fxd, film 42.2 1% 1/8W	1	CEA-993	07716	0757-0316	1
R92	Thermistor, 64 Ω at 25°C	1	LB16J1	73168	0837-0023	1
U1-3	Operational Amplifier, IC	3	LM301AH	27014	1820-0223	3
VR1, 2	Diode, zener 6.19V	2	CD35646	15818	1902-0049	2
VR3	Diode, zener 4.32V	1	SZ11213-35	04713	1902-0797	1
VR4	Diode, zener 3.74V	1	CD35582	15818	1902-0062	1
VR5	Diode, zener 6.2V	1	1N825	28480	1902-1221	1
VR6	Diode, zener 16.2V	1	SZ10939-242	04713	1902-0184	1
VR7						
6177C	Diode, zener 61.9V	1	SZ11213-368	04713	1902-0660	1
6181C	Diode, zener 150V	2	SZ11213-440	04713	1902-0586	2

Table 6-4. Replaceable Parts

REF. DESIG.	DESCRIPTION	TQ*	MFR. PART NO.	MFR. CODE	HP PART NO.	RS*
VR10	Diode, zener 2.37V	1	SZ10939-2	04713	1902-3002	1
VR12	Diode, zener 5.6V	1	1N755	28480	1902-3104	1
VR14						
6177C	Diode, zener 42.2V	1	1N976	28480	1902-3323	1
6181C	(not used)					
VR15						
6177C	Diode, zener 20.5V	1	1N968	28480	1902-0182	1
6181C	Diode, zener 150V		SZ11213-440	04713	1902-0586	
<u>Chassis, Electrical</u>						
DS1	Neon lamp (LINE)	1	A1C	08806	2140-0047	1
DS2	Light-emitting diode (LIMIT)	1		28480	1990-0325	1
F1	Fuse 1A 250V (115V operation)	1	312001	75915	2110-0001	5
M1						
6177C	Meter, 0-600mA, 0-60Vdc	1		28480	1120-1147	
6181C	Meter, 0-300mA, 0-120Vdc	1		28480	1120-1148	
Q6						
6177C	Power NPN Si.	1	37577	02735	1854-0239	1
6181C	Power NPN Si.	4	60128	02735	1854-0421	4
Q25, 29, 30						
6177C	Power NPN Si.	3	37578	02735	1854-0250	3
6181C	Power NPN Si.		60128	02735	1854-0421	
R40						
6177C	Var, ww 2K 10-turn	1		28480	2100-2029	1
6181C	Var, ww 5K 10-turn	1		28480	2100-1865	1
R81	Var, cermet 50K	1	Series 550	71450	2100-2023	1
R93	fxd, comp 47K 5% 1/2W	1	EB4735	01121	0686-4735	1
S1	Switch, rotary, line/meter	1		28480	3100-1936	1
S2	Switch, rotary, current range	1		28480	3100-1935	1
S3	Switch, slide DPDT	1	11A-1242A	82389	3101-1234	1
T1	Power transformer	1		28480	5080-1798	1
<u>A1 Input Board, Mechanical</u>						
	PC board edge connector	1	252-06-30-340	71785	1251-0478	
	Fuseholder clip	2	6008-32CN	91506	2110-0269	
<u>A2 Main Board, Mechanical</u>						
	Barrier strip, 5-term.	1		28480	0360-1550	
	Barrier strip, 4-term.	1		28480	0360-1551	
	Barrier strip jumper	3	422-13-11-013	71785	0360-1143	
	Transistor mounting pad	6	7717-5-N	13103	1200-0181	
	Socket, integrated circuit	3	133-98-92-061	71785	1200-0763	
	Heat Sink (Q1)	1		28480	5000-9316	
	Heat dissipators (Q27, 28)	2	207-CB	05820	1205-0033	
<u>Front Panel, Mechanical</u>						
	Pin jack, white (+ METER)	1	105-601	74970	1251-2440	
	Binding post (red)	2		28480	1510-0094	
	Binding post (black)	1		28480	1510-0522	
	Hex nut, binding post (nylon)	3	913-891	26365	2950-0144	
	Meter bezel	1		28480	4040-0571	
	Spring, meter mount	4		28480	1460-0720	
	Lampholder base (DS1)	1		28480	5040-0305	
	Lampholder clip (DS1)	1		28480	5040-0234	
	Mounting clip (DS2)	1	7219-19-1-A001	0016G	1400-0532	

Table 6-4. Replaceable Parts

REF. DESIG.	DESCRIPTION	TQ*	MFR. PART NO.	MFR. CODE	HP PART NO.	RS*
	<u>Front Panel, Mechanical (Cont.)</u>					
	Retaining ring (DS2)	1	7212-19-1-A002	0016G	1400-0540	
	Knob, pointer (S1, 2, R81)	3		28480	0370-1099	
	Knob, plain (R40)	1		28480	0370-1136	
	Hex nut, control shaft	4	76320-NP	73734	0590-0856	
	<u>Rear Panel, Mechanical</u>					
	Strain relief, line cord	1	SR-5P-4	28520	0400-0013	
	Line cord	1	KH4096	70903	8120-0050	
	Barrier strip cover	1		28480	5020-5755	
	Fuseholder	1	342014	75915	1400-0084	
	Lockwasher, fuseholder	1	1924-12	78189	2190-0054	
	Heat sink	1		28480	5020-8067	
	Insulator, heat sink mount	4		28480	0340-0172	
	Insulator, boron nitride	4	H-4001	61637	0340-0411	
	Transistor insulator, molded	4		28480	0340-0795	
	<u>Miscellaneous</u>					
	Center chassis	1		28480	5000-3092	
	Rear panel	1		28480	5000-3097	
	Front panel, basic	1		28480	5020-5753	
	Front panel, control insert (6177C)	1		28480	06177-60009	
	(6181C)	1		28480	06181-60009	
	Front panel, output insert (6177C)	1		28480	06177-60007	
	(6181C)	1		28480	06181-60007	
	Side Frame Assembly	2		28480	5060-0700	
	Tilt stand	1		28480	1490-0032	
	Tilt stand hinge	2		28480	5040-0700	
	Foot assembly	1		28480	5060-0728	
	Side frame assembly spacer	2		28480	5020-0701	
	Side cover	2		28480	5000-8559	
	Bottom cover	1		28480	5000-9444	
	Top cover	1		28480	5060-8585	
	Connector, heat sink assy, 10-position	1		28480		
	Connector, front panel assy, 21-position	1		28480	1251-4054	
	Polarizing key (for 10-pos and 21-pos connectors)	2		28480		
	Packing carton	1		28480	9211-0848	
	Floater pad, packing	2		28480	9220-1218	

Table 6-4. Replaceable Parts

REF. DESIG.	DESCRIPTION	TQ*	MFR. PART NO.	MFR. CODE	HP PART NO.	RS*
	Option 014 3-Digit decadal Current Control 3-Digit decadal Flatwasher	1 1	RD411	07716 28480	1140-0020 06177-00006	
F1	Option 028 230-Volt Input Fuse, 1/2A, 250V	1	312.500	75915	2110-0012	

Note: There are no exact commercial replacements for Q27 or Q28 in the 6177C or for Q32 in both models. The alternate commercial equivalents listed below can be tried with a high probability of success and may be used if the listed HP part is not immediately available.

Q27, Q28 (6177C)	SS1147 (Motorola)
Q32 (6177C and 6181C)	2N6028

SECTION VII CIRCUIT DIAGRAM

This section contains component location diagrams and a schematic diagram of the power supply. The component location diagrams show the physical locations and reference designators of parts mounted on the printed cir-

cuit boards. On the schematic, voltages are given in italics adjacent to test points, which are identified by circled numbers both on the schematic and on the component location diagrams.

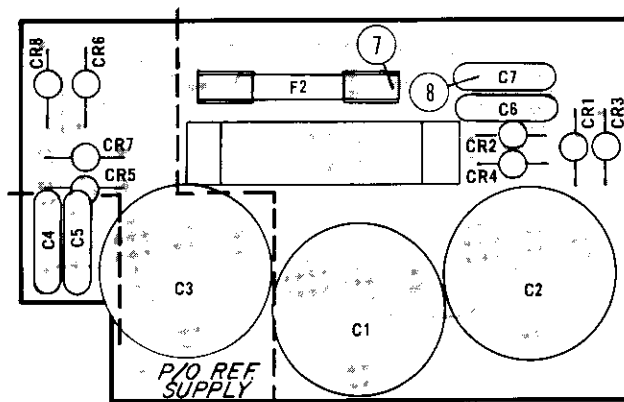

Figure 7-1. A1 Input Board (6177C), Component Locations

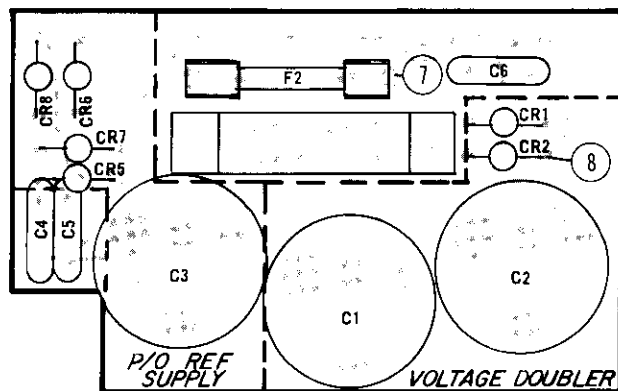

Figure 7-2. A1 Input Board (6181C), Component Locations

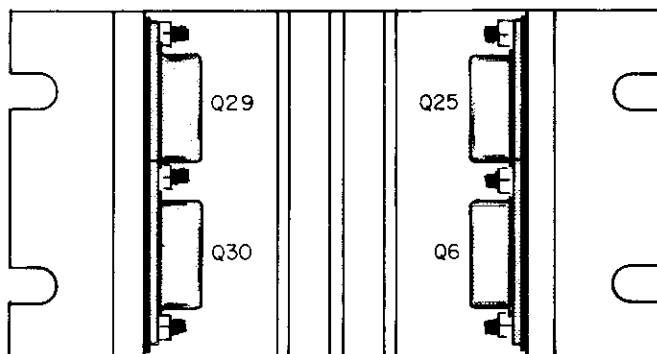

Figure 7-3. Heatsink Assembly, Transistor Locations

SAFETY SUMMARY

The following general safety precautions must be observed during all phases of operation, service, and repair of this instrument. Failure to comply with these precautions or with specific warnings elsewhere in this manual violates safety standards of design, manufacture, and intended use of the instrument. Hewlett-Packard Company assumes no liability for the customer's failure to comply with these requirements.

BEFORE APPLYING POWER.

Verify that the product is set to match the available line voltage and the correct fuse is installed.

GROUND THE INSTRUMENT.

This product is a Safety Class 1 instrument (provided with a protective earth terminal). To minimize shock hazard, the instrument chassis and cabinet must be connected to an electrical ground. The instrument must be connected to the ac power supply mains through a three-conductor power cable, with the third wire firmly connected to an electrical ground (safety ground) at the power outlet. For instruments designed to be hard-wired to the ac power lines (supply mains), connect the protective earth terminal to a protective conductor before any other connection is made. Any interruption of the protective (grounding) conductor or disconnection of the protective earth terminal will cause a potential shock hazard that could result in personal injury. If the instrument is to be energized via an external autotransformer for voltage reduction, be certain that the autotransformer common terminal is connected to the neutral (earthed pole) of the ac power lines (supply mains).

INPUT POWER MUST BE SWITCH CONNECTED.

For instruments without a built-in line switch, the input power lines must contain a switch or another adequate means for disconnecting the instrument from the ac power lines (supply mains).

DO NOT OPERATE IN AN EXPLOSIVE ATMOSPHERE.

Do not operate the instrument in the presence of flammable gases or fumes.

KEEP AWAY FROM LIVE CIRCUITS.

Operating personnel must not remove instrument covers. Component replacement and internal adjustments must be made by qualified service personnel. Do not replace components with power cable connected. Under certain conditions, dangerous voltages may exist even with the power cable removed. To avoid injuries, always disconnect power, discharge circuits and remove external voltage sources before touching components.

DO NOT SERVICE OR ADJUST ALONE.

Do not attempt internal service or adjustment unless another person, capable of rendering first aid and resuscitation, is present.

Instruments which appear damaged or defective should be made inoperative and secured against unintended operation until they can be repaired by qualified service personnel.

DO NOT EXCEED INPUT RATINGS.

This instrument may be equipped with a line filter to reduce electromagnetic interference and must be connected to a properly grounded receptacle to minimize electric shock hazard. Operation at line voltages or frequencies in excess of those stated on the data plate may cause leakage currents in excess of 5.0 mA peak.

SAFETY SYMBOLS.



Instruction manual symbol: the product will be marked with this symbol when it is necessary for the user to refer to the instruction manual (refer to Table of Contents).



Indicates hazardous voltages.



or



Indicate earth (ground) terminal.

WARNING

The WARNING sign denotes a hazard. It calls attention to a procedure, practice, or the like, which, if not correctly performed or adhered to, could result in personal injury. Do not proceed beyond a WARNING sign until the indicated conditions are fully understood and met.

CAUTION

The CAUTION sign denotes a hazard. It calls attention to an operating procedure, or the like, which, if not correctly performed or adhered to, could result in damage to or destruction of part or all of the product. Do not proceed beyond a CAUTION sign until the indicated conditions are fully understood and met.

DO NOT SUBSTITUTE PARTS OR MODIFY INSTRUMENT.

Because of the danger of introducing additional hazards, do not install substitute parts or perform any unauthorized modification to the instrument. Return the instrument to a Hewlett-Packard Sales and Service Office for service and repair to ensure that safety features are maintained.

MANUAL CHANGES
 Model 6177C and 6181C Precision Constant Current Source
 Manual HP P/N 5950-1749

Make all corrections in the manual according to errata below, then check the following table for your power supply serial number and enter any listed changes(s) in the manual.

Model 6177C

SERIAL		MAKE CHANGES
Prefix	Number	
1525A	00128-00147	2
1551A	00148-00167	2,3
1610A	00168-00267	2,3,4
1707A	00268-01157	2-5
2238A	01158-01217	2-5,7
2314A	01218-01247	2-5,7,8
2339A	01248-up	2-5,7,8,9

CHANGE 1:

In the parts list and on schematic for Model 6181C, make the following changes: Under A2 Main Board: change R87 to 100 k, 1%, 1/2 W, HP P/N 0757-0367. Change R88 to 4.7M, 1/4 W, HP P/N 0683-4755.

CHANGE 2:

Make the following changes to the schematic and the parts list for the Model 6177C:

- Change R9 to 180 ohm, 0686-1815.
- Change R38 to 330 ohm, 0698-3631.

CHANGE 3:

The cable assemblies that connect the heatsink assembly and the front panel assembly to the main PC board are now prefabricated. Under Miscellaneous in the parts list, delete both connectors and the polarizing key and add the following:

- heatsink cable assembly 5060-2692
- front panel cable assembly 5060-2691

The heatsink cable assembly includes eight 1251-4223 crimp terminals, one 1251-4224 10-contact connector, and one 1251-3942 polarizing key for the connector. The front panel cable assembly includes twenty 1251-4225 crimp terminals, one 1251-4025 20-contact connector, and one 1251-3942 polarizing key for the connector.

Model 6181C

SERIAL		MAKE CHANGES
Prefix	Number	
1525A	00109-0188	1
1603A	00189-0308	1,3,4
1653A	00309-0648	1,3,4,5
1915A	00649-1328	1,3,4,5,6
2238A	01329-1403	1,3-7
2313A	01404A-up	1,3-8

CHANGE 4:

Pilot lamp DS1 and resistor R93 are now connected as shown below. With this connection the lamp remains at 115 Vac for either input (115 Vac or 230 Vac). Previously, the lamp and resistor were connected across the input voltage.

The following changes allow the units' load regulation specification to be maintained during remote programming.

Delete Figure 3-7. An external voltmeter cannot be connected to terminal Ao on rear terminal strip because the external meter current would degrade load regulation. Change paragraph 3-30 to read: "External voltage monitoring cannot be connected to rear barrier strip Ao. External voltage monitoring can only be connected to + METER output jack on the front panel."

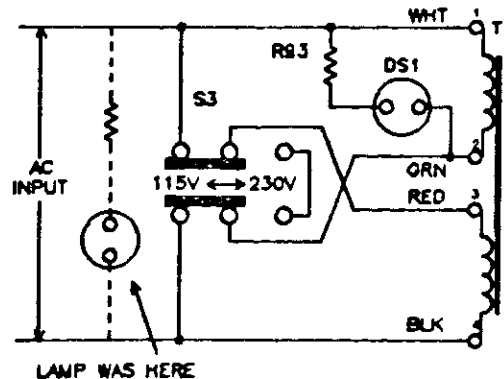

ERRATA:

Change the part number for knob, plain (R40) to 0370-1091.

The front panel binding posts have been changed to a type with better designed insulation. Delete the two types of posts listed on page 6-9 of the parts list and add: black binding post, HP P/N 1510-0114 (qty 1); and red binding post HP P/N 1510-0115 (qty 2).

CHANGE 5:

Line voltage selector switch S3 has been relocated to reduce common mode output ripple. On page 6-10, change the HP P/N of the center chassis to 5000-3136.

ERRATA:

Effective January 1, 1977, Option 014 (decadial for 10-turn current control) has been redesignated Option 015. Make this change wherever Option 014 is mentioned in the manual.

CHANGE 6:

In parts list and on schematic for 6181C, change R7 to 1.3 k, HP P/N 0686-1325. This change was also implemented on serial numbers 1653A-00629, 00630, 00631, 00635, 00645, and 00648.

ERRATA:

For all instruments delivered on or after July 1, 1978, change the HP P/N for fuseholder from 1400-0084 to fuseholder body 2100-0564 and fuseholder carrier 2100-0565. Change the HP P/N for fuseholder nut from 2950-0038 to 2110-0569. If old fuseholder must be replaced for any reason, replace complete fuseholder and nut with new fuseholder parts. Do not replace new parts with old parts.

In the replaceable parts list and on the schematic, change the variable resistors. R46 and R56 to 20 k ohm, 1/2 W, HP P/N 2100-0558.

On page 6-10, change: Bottom cover to HP P/N 5000-9368 qty 1. Top cover to HP P/N 5000-9367 qty 1.

CHANGE 7:

In the parts list and on the schematic, change VR4 to 4.22 V, 5% HP P/N 1902-3070.

CHANGE 8:

In the replaceable parts list, page 6-10, under Front Panel Mechanical (cont.), delete Knob, plain (R40) which was changed in a previous ERRATA to HP P/N 0370-1091. In its place add, Decadial HP P/N 1140-0020 Qty.1.

CHANGE 9:

In the replaceable parts list, page 6-7 and on the schematic Figure 7-5 change R66 to 56 ohm, 5%, HP P/N 0686-5605.

ERRATA:

When required, it is recommended that R66 be replaced with HP P/N 0686-5605.

ERRATA:

On page 6-9, under A2 Main Board, Mechanical, change Barrier strip, 5-term. to HP P/N 0360-2177, and Barrier strip 4 term. to HP P/N 0360-1551.

9-19-83